



<https://mail.gptcthirurangadi.in>

# **ELECTRONIC CIRCUITS LAB**



<https://mail.gptcthirurangadi.in>



## STATE INSTITUTE OF TECHNICAL TEACHERS TRAINING AND RESEARCH

### GENERAL INSTRUCTIONS

Rough record and Fair record are needed to record the experiments conducted in the laboratory. Rough records are needed to be certified immediately on completion of the experiment. Fair records are due at the beginning of the next lab period. Fair records must be submitted as neat, legible, and complete.

#### INSTRUCTIONS TO STUDENTS FOR WRITING THE FAIR RECORD

In the fair record, the index page should be filled properly by writing the corresponding experiment number, experiment name, date on which it was done and the page number.

On the **right side** page of the record following has to be written:

1. **Title:** The title of the experiment should be written in the page in capital letters.
2. In the left top margin, experiment number and date should be written.
3. **Aim:** The purpose of the experiment should be written clearly.
4. **Apparatus/Tools/Equipments/Components used:** A list of the Apparatus/Tools/ Equipments /Components used for doing the experiment should be entered.
5. **Principle:** Simple working of the circuit/experimental set up/algorithm should be written.
6. **Procedure:** steps for doing the experiment and recording the readings should be briefly described(flow chart/programs in the case of computer/processor related experiments)
7. **Results:** The results of the experiment must be summarized in writing and should be fulfilling the aim.
8. **Inference:** Inference from the results is to be mentioned.

On the **Left side** page of the record following has to be recorded:

1. **Circuit/Program:** Neatly drawn circuit diagrams/experimental set up.
2. **Design:** The design of the circuit/experimental set up for selecting the components should be clearly shown if necessary.



### 3. Observations:

- i) Data should be clearly recorded using Tabular Columns.
- ii) Unit of the observed data should be clearly mentioned
- iii) Relevant calculations should be shown. If repetitive calculations are needed, only show a sample calculation and summarize the others in a table.

4. **Graphs:** Graphs can be used to present data in a form that shows the results obtained, as one or more of the parameters are varied. A graph has the advantage of presenting large amounts of data in a concise visual form. Graphs should be in a square format.

### GENERAL RULES FOR PERSONAL SAFETY

1. Always wear tight shirt/lab coat, pants and shoes inside workshops.
2. REMOVE ALL METAL JEWELLERY since rings, wrist watches or bands, necklaces, etc. make excellent electrodes in the event of accidental contact with electric power sources.
3. DO NOT MAKE CIRCUIT CHANGES without turning off the power.
4. Make sure that equipment working on electrical power are grounded properly.
5. Avoid standing on metal surfaces or wet concrete. Keep your shoes dry.
6. Never handle electrical equipment with wet skin.
7. Hot soldering irons should be rested in its holder. Never leave a hot iron unattended.
8. Avoid use of loose clothing and hair near machines and avoid running around inside lab.

### TO PROTECT EQUIPMENT AND MINIMIZE MAINTENANCE:

**DO:** 1. SET MULTIRANGE METERS to highest range before connecting to an unknown source.

2. INFORM YOUR INSTRUCTOR about faulty equipment so that it can be sent for repair.

**DO NOT:** 1. Do not MOVE EQUIPMENT around the room except under the supervision of an instructor.



## Experiment No. 1

### RC DIFFERENTIATOR

#### AIM

To design and construct RC differentiator circuit and study its pulse response.

#### OBJECTIVES

On completion of the experiment students will be able to

- ❖ design differentiator circuit for a given frequency
- ❖ understand the behavior of the circuit for various inputs

#### EQUIPMENTS / COMPONENTS

Sl. no.	Name and specification	Quantity
1.	Capacitor 0.001 $\mu$ F	1 no.
2.	Resistor 1 K $\Omega$	1 no.
3.	Function generator 0 to 1 MHz	1 no.
4.	Oscilloscope 0 to 20 MHz	1 no.
5.	Multimeter	1 no.
6.	Breadboard	1 no.
7.	Connecting wires	

#### PRINCIPLE

An RC differentiator circuit is a wave shaping circuit. It constitutes a capacitor in series and a resistor in parallel at the output. The time constant ( $R \times C$ ) of the circuit is very small in comparison with the period of the input signal. As the name shows the circuit does the mathematical operation 'differentiation' on the input signal. At the time of differentiation the voltage drop across R will be very small in comparison with the drop across C.

Differentiated output is proportional to the rate of change of input. When the input rises to maximum value, differentiated output follows it, because the sudden change of voltage is transferred to the output by the capacitor. Since the rate of change of voltage is positive, differentiated output is also positive. When the input remains maximum for a period of time the rate of change of voltage is zero ( $\frac{d}{dt}$  of constant = Zero). During this time input acts like a dc voltage and capacitor blocks it (At this time the charge stored in the capacitor previously, discharges through R). When input falls to zero, rate of change is negative. Thus the output also goes to negative.

For perfect differentiation  $RC < 0.0016T$  where  $T = \frac{1}{f}$  and f is the frequency of input signal.



## PROCEDURE

- 1) Test the components
- 2) Assemble the circuit on a breadboard
- 3) Connect the output of a function generator to the input of the differentiator circuit
- 4) Switch on the function generator and set the input at 5V, 1KHz pulse
- 5) Connect the output of the differentiator to an oscilloscope
- 6) Observe the output waveform and its amplitude for the following condition by varying the time period (T) of the input
  - (i)  $RC \ll T$  ( $f = 1$  KHz) that is  $RC \ll 0.0016T$
  - (ii)  $RC < T$  ( $f = 100$  KHz)
  - (iii)  $RC > T$  ( $f = 1$  MHz)
- 7) Study the behavior of the circuit for different values of T
- 8) Plot all the input and output waveforms

## CIRCUIT DIAGRAM

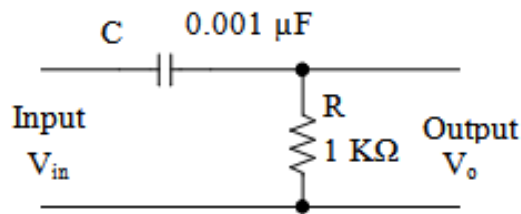

## DESIGN

Let the input be a square pulse of 1 KHz

Then  $T = 1\text{ms}$

For a differentiator  $RC \leq 0.0016T$

To avoid loading select R as 10 times the output impedance of the function generator

If it is  $100\ \Omega$ , then  $R = 1\text{K}\Omega$

Substituting the values in the above expression, we get  $C = 0.0016\mu\text{F}$

Take  $C = 0.001\mu\text{F}$  (Then RC value i.e. time constant of the above circuit is  $1\mu\text{s}$ )

## OBSERVATIONS

To observe the response of the circuit, you can change either the RC value of the circuit or T of the input. Here T of the input is changed.

1.  $f = 1$  KHz,  $T = \frac{1}{f} = 1\text{ms}$ ,  $RC = 1\mu\text{s}$  ( $RC \ll T$ )

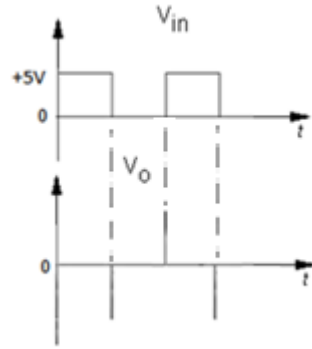

2.  $f = 100 \text{ KHz}$ ,  $T = \frac{1}{f} = 0.01\text{ms}$ ,  $RC = 1\mu\text{s}$  ( $RC < T$ )

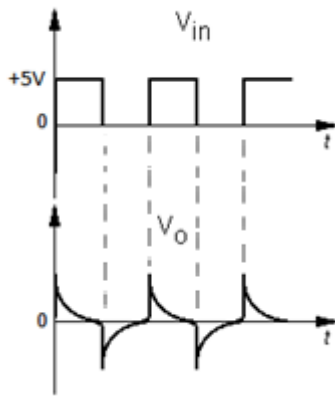

3.  $f = 1 \text{ MHz}$ ,  $T = \frac{1}{f} = 1\mu\text{s}$ ,  $RC = 1\mu\text{s}$  ( $RC \geq T$ )

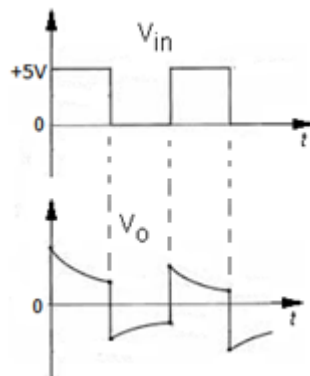

**RESULT:**

**INFERENCE:**



<https://mail.gptcthirurangadi.in>





## Experiment No. 2

### RC INTEGRATOR

#### AIM

To design and construct RC integrator circuit and study its pulse response.

#### OBJECTIVES

On completion of the experiment students will be able to

- ❖ design integrator circuit for a given frequency
- ❖ understand the behavior of the circuit for various inputs

#### EQUIPMENTS / COMPONENTS

Sl. no.	Name and specification	Quantity
1.	Capacitor 22 $\mu$ F	1 no.
2.	Resistor 1 K $\Omega$	1 no.
3.	Function generator 0 to 1 MHz	1 no.
4.	Oscilloscope 0 to 20 MHz	1 no.
5.	Multimeter	1 no.
6.	Breadboard	1 no.
7.	Connecting wires	

#### PRINCIPLE

An RC integrator circuit is a wave shaping circuit. It constitutes a resistor in series and a capacitor in parallel to the output. As the name suggests it does the mathematical operation 'integration' on the input signal. The time constant RC of the circuit is very large in comparison with the time period of the input signal. Under this condition the voltage drop across C will be very small in comparison with the voltage drop across R. For satisfactory integration it is necessary that  $RC \geq 16T$ , where T is time period of the input.

When pulse waveform is given at the input, capacitor charges through R and output voltage builds up slowly. Capacitor continues to charge as long as input voltage is present. When input falls to zero, capacitor discharges and output falls to zero slowly. As the value of  $RC \gg T$ , the charging current is almost constant and the output become linear. Hence a square pulse input provides a triangular output.

#### PROCEDURE

- 1) Test the components
- 2) Assemble the circuit on a breadboard



- 3) Connect the output of a function generator to the input of the differentiator circuit
- 4) Switch on the function generator and set the output at 5V, 1KHz pulse
- 5) Connect the output of the differentiator to an oscilloscope
- 6) Observe the output waveform and its amplitude for the following condition by varying the time period (T) of the input

- (i)  $RC \gg T$  ( $f = 1 \text{ KHz}$ ) that is  $RC \gg 16T$
- (ii)  $RC > T$  ( $f = 100 \text{ Hz}$ )
- (iii)  $RC < T$  ( $f = 10 \text{ Hz}$ )
- (iv)  $RC \ll T$  ( $f = 1 \text{ Hz}$ )

- 7) Study the behavior of the circuit for different values of T
- 8) Plot all the input and output waveforms

### CIRCUIT DIAGRAM

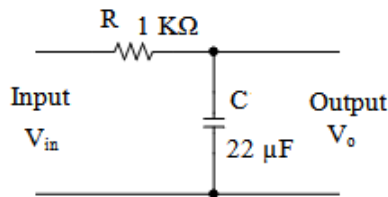

### DESIGN

Let the input be a square pulse of 1 KHz

Then  $T = 1 \text{ ms}$

For an integrator  $RC \geq 16T$

To avoid loading select R as 10 times the output impedance of the function generator

If it is  $100 \Omega$ , then  $R = 1 \text{ K}\Omega$

Substituting the value of R in the expression,  $RC = 16T$ , we get  $C = 16 \mu\text{F}$

Therefore C should be greater than  $16 \mu\text{F}$ . Hence choose  $C = 22 \mu\text{F}$

### OBSERVATIONS

To observe the response of the circuit, you can change either the RC value of the circuit or T of the input. Here T of the input is changed.

1.  $f = 1 \text{ KHz}$ ,  $T = \frac{1}{f} = 1 \text{ ms}$ ,  $RC = 22 \text{ ms}$  ( $RC \gg T$ )

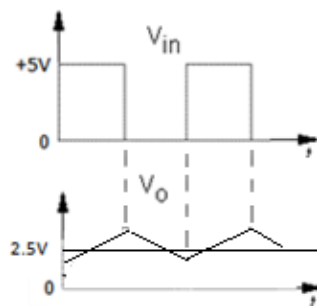

2.  $f = 100 \text{ KHz}$ ,  $T = \frac{1}{f} = 10\text{ms}$ ,  $RC = 22\text{ms}$  ( $RC > T$ )

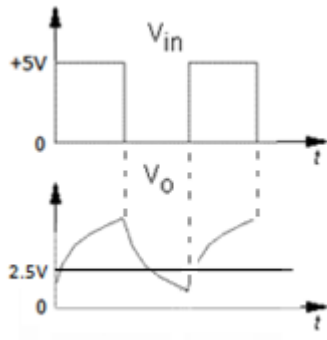

3.  $f = 10 \text{ Hz}$ ,  $T = \frac{1}{f} = 100\text{ms}$ ,  $RC = 22\text{ms}$  ( $RC < T$ )

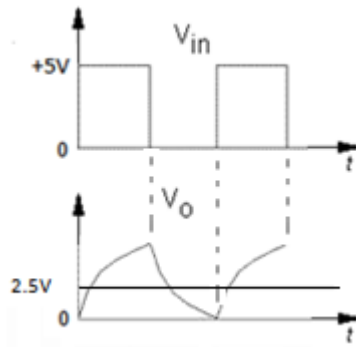

4.  $f = 1 \text{ Hz}$ ,  $T = \frac{1}{f} = 1\text{s}$ ,  $RC = 22\text{ms}$  ( $RC \ll T$ )

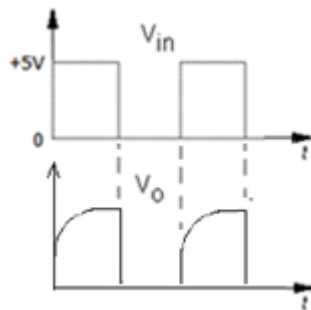

**RESULT:**

**INFERENCE:**



<https://mail.gptcthirurangadi.in>



## Experiment No. 3

### TRANSISTOR AS SWITCH

#### AIM

Set up a transistor switch and observe its performance in low frequency and in high frequency

#### OBJECTIVES

On completion of the experiment students will be able to

- ❖ Check the dc condition of normally ON switch and normally OFF switch
- ❖ Understand the response at low frequency
- ❖ Make switching circuits for various applications
- ❖ Understand the response at high frequency

#### EQUIPMENTS / COMPONENTS

Sl. no.	Name and Specification	Quantity
1.	Resistors 1 K $\Omega$ 100 K $\Omega$ 47 K $\Omega$	1 no. 1 no. 1 no.
2.	Transistor BC 107	1 no.
3.	LED	1 No
3.	Function generator 0 to 1 MHz	1 no.
4.	Oscilloscope 0 to 20 MHz	1 no.
5.	Multimeter	1 no.
6.	Breadboard	1 no.
7.	Connecting wires	

#### PRINCIPLE

Transistor can function as a switch and provide output voltage level either high or low. When a transistor is used as a switch, it operates in two regions known as saturation and cut off. When transistor is in saturation, the voltage at the collector will be very low ( $V_{ce\ sat}$ ). This is called ON state. ( $I_c$  is maximum). At this time  $I_b > \frac{I_c}{\beta}$ . If the transistor is biased to cut off, the output voltage at the collector will be high ( $V_{cc}$ ). This is called OFF state ( $I_c = 0$ ). CE configuration is most suitable for a transistor switch because the current and voltage needed to the input switching signal are very small.



**Normally OFF Transistor switch :** Here the base resistor is not connected to VCC. At this time  $V_{be} = 0$ ,  $V_{ce} = V_{cc}$ . For an NPN transistor a positive voltage at the base will switch the transistor into saturation state.

At high frequencies transistors have finite switching delays due to the diffusion of charge carriers. Various switching delays are

- (a) Delay time ( $t_d$ ) – Time elapsed for the output voltage to reach 10% of the maximum value after the input voltage is applied
- (b) Rise time ( $t_r$ ) – It is the time taken by the output voltage to rise from 10% to 90% of its maximum value.
- (c) Storage time ( $t_s$ ) – Time elapsed by the output voltage to fall to 90% of its maximum value
- (d) Fall time ( $t_f$ ) – It is the time taken by the output voltage to fall to 90% to 10% of its maximum value.

$$\text{ON time } (t_{on}) = t_d + t_r$$

$$\text{OFF time } (t_{off}) = t_f + t_s$$

## PROCEDURE

- 1) Test the components
- 2) Assemble the circuit on a breadboard
- 3) Measure the dc condition that is  $V_{BE}$  and  $V_{CE}$  using multimeter and verify the transistor is in ON condition.
- 4) Apply 1KHz, 10V<sub>pp</sub> square wave as input
- 5) Observe and plot the waveforms at base and collector
- 6) Connect an LED at the collector and visualize the switching action with 5Hz signal

## CIRCUIT DIAGRAM

1. DC condition

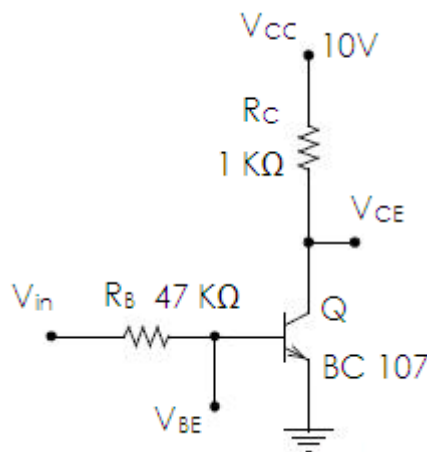

2. Square wave response

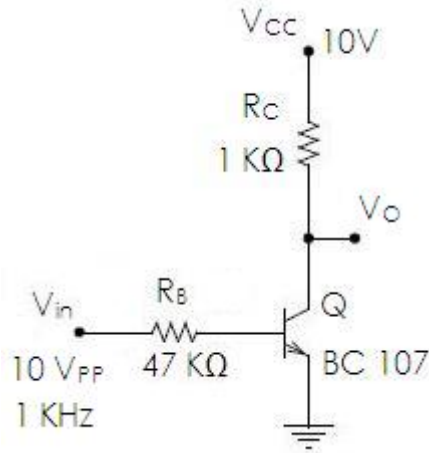

3. Visualization with LED

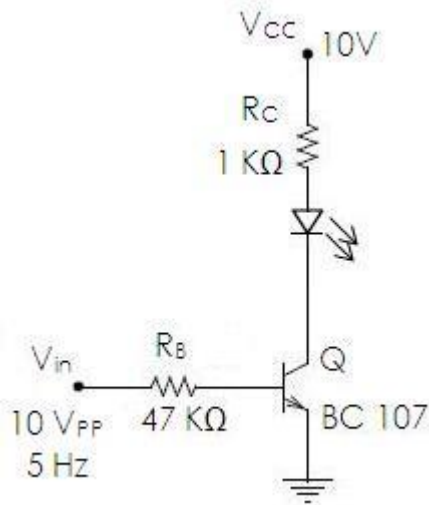

**OBSERVATIONS**

1. DC condition

$$V_{BE} =$$

$$V_{CE} =$$

2. Square wave response
3. Visualization with LED

LED turns ON and OFF 5 times in one second

**RESULT:**

**INFERENCE:**



<https://mail.gptcthirurangadi.in>





## Experiment No. 4

### SINGLE STAGE RC COUPLED AMPLIFIER

#### AIM

To set up a single stage RC coupled CE amplifier with potential divider bias and

- (i) Observe the phase difference between input and output waveforms
- (ii) Measure mid band gain
- (iii) Plot its frequency response and determine the bandwidth

#### OBJECTIVES

On completion of the experiment students will be able to

- ❖ assemble a transistor amplifier circuit
- ❖ test the dc condition and ascertain the working condition of the amplifier
- ❖ understand the characteristics of CE amplifier
- ❖ understand the characteristics of RC coupled amplifier
- ❖ calculate the gain of amplifier
- ❖ role of coupling capacitor or blocking capacitor

#### EQUIPMENTS / COMPONENTS

Sl. no.	Name and Specification	Quantity	
1.	Resistors	470 $\Omega$	1 no.
		1 K $\Omega$	1 no.
		1.8 K $\Omega$	1 no.
		10 K $\Omega$	1 no.
		47 K $\Omega$	1 no.
2.	Capacitor	10 $\mu$ F	2 nos.
		22 $\mu$ F	1 no.
3.	Transistor	BC 107	1 no.
4.	Function generator	0 to 1 MHz	1 no.
5.	Oscilloscope	0 to 20 MHz	1 no.
6.	Power supply	12 V dc	1 no.
7.	Multimeter		1 no.
8.	Breadboard		1 no.
9.	Connecting wires		



## PRINCIPLE

RC coupled CE amplifier is widely used in audio frequency applications as voltage amplifiers. In a CE amplifier base current controls the collector current. A small change in  $I_B$  results in relatively large change in  $I_C$ . The transistor is biased in active region using potential divider bias. That is emitter - base junction is forward biased and collector - base junction is reverse biased.

The output signal is  $180^\circ$  out of phase with input signal. RC coupled amplifier provides uniform gain at mid frequencies. Gain decreases at low frequencies and high frequencies. The output voltage and hence the voltage gain is decided by  $R_L$ .

$$\text{Voltage gain, } A_V = \beta \frac{Z_{in}}{Z_{out}}$$

But  $Z_{in} = R_1 \parallel R_2 \parallel R_{in}$  and is approximately equal to  $R_{in}$  (typically  $1 \text{ K}\Omega$ ), where  $R_{in}$  is the input dynamic resistance of transistor. Similarly  $Z_{out} = R_C \parallel R_L \parallel R_O$ , where  $R_O$  is the output dynamic resistance of transistor. Since  $R_O \gg R_C$  and  $R_L$ ,  $Z_{out} = R_C \parallel R_L = R_{ac}$ . Therefore Voltage gain  $A_V = \beta \frac{R_{ac}}{R_{in}}$ . Since  $R_{in}$  is constant, voltage gain decreases with decrease in  $R_L$ .

## PROCEDURE

- 1) Test the components
- 2) Assemble the circuit in a bread board
- 3) Give  $V_{CC}$  and measure the dc bias conditions
- 4) Give  $1 \text{ KHz}$ ,  $50 \text{ mV}$  (pp) sinusoidal signal as input, observe and plot the waveforms at collector and at the output point
- 5) Then measure the output voltage without  $R_L$ , with  $R_L = 10 \text{ K}\Omega$  and with  $R_L = 1 \text{ K}\Omega$
- 6) Calculate the voltage gain in each case
- 7) To get the frequency response vary the input frequency from  $0 - 1 \text{ MHz}$  in suitable steps and measure the output voltage in each step
- 8) Enter these values in tabular column and plot the frequency response in a graph sheet
- 9) Determine the midband gain and bandwidth from the frequency response plot

## CIRCUIT DIAGRAM

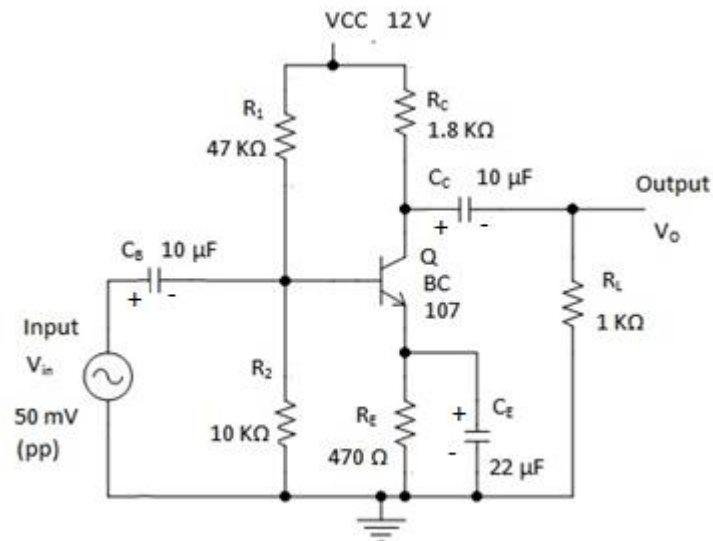



## OBSERVATIONS

### 1. DC conditions

$$V_{CC} =$$

$$V_{BE} =$$

$$V_{CE} =$$

### 2. Input and output waveforms

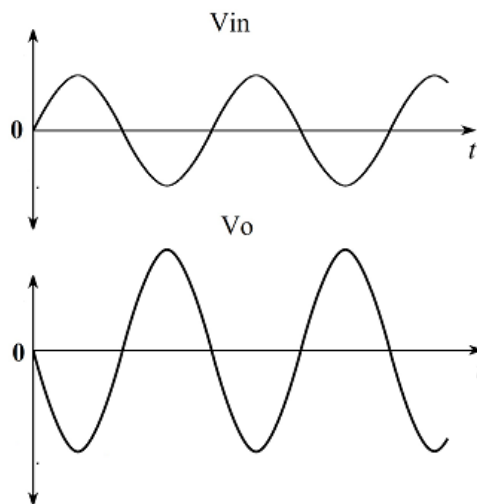

### 3. Calculation of gain at midband

(i) Without  $R_L$

$$V_{in} = 50 \text{ mV (pp)}$$

$$F = 10 \text{ KHz}$$

$$\text{Gain} = \frac{V_o}{V_{in}} =$$

(ii) Without  $R_L = 10 \text{ K}\Omega$

$$V_{in} = 50 \text{ mV (pp)}$$

$$F = 10 \text{ KHz}$$

$$\text{Gain} = \frac{V_o}{V_{in}} =$$

(iii) Without  $R_L = 1 \text{ K}\Omega$

$$V_{in} = 50 \text{ mV (pp)}$$

$$F = 10 \text{ KHz}$$



$$\text{Gain} = \frac{V_o}{V_{in}}$$

(Note : It can be seen that as the value of RL decreases gain also decreases)

#### 4. Frequency response

Frequency (f) in Hz	Log f	V <sub>o</sub> in Volt	Gain = $\frac{V_o}{V_{in}}$	Gain in dB 20 log (Gain)

#### 5. Frequency response plot

Take log f on x-axis, gain in dB on y-axis

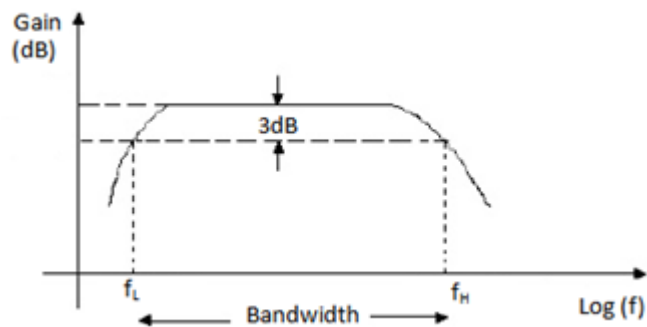

From frequency response plot

$$f_L =$$

$$f_H =$$

$$\text{Bandwidth} = f_H - f_L$$

$$\text{Midband gain} =$$

**RESULT:**

**INFERENCE:**



## Experiment No. 5

### EMITTER FOLLOWER

#### AIM

To construct an emitter follower circuit and

- (i) Measure the gain
- (ii) Plot its input and output waveforms

#### OBJECTIVES

On completion of the experiment students will be able to

- ❖ Assemble an emitter follower circuit
- ❖ Test the dc condition and ascertain the working condition of the amplifier
- ❖ Understand the characteristics of emitter follower circuit

#### EQUIPMENTS / COMPONENTS

Sl. no.	Name and Specification	Quantity	
1.	Resistors	1 K $\Omega$	1 no.
		2.2 K $\Omega$	1 no.
		10 K $\Omega$	1 no.
		22 K $\Omega$	1 no.
		33 K $\Omega$	1 no.
2.	Capacitor	1 $\mu$ F	2Nos
3.	Transistor	BC 107	1 no.
4.	Function generator	0 to 1 MHz	1 no.
5.	Oscilloscope	0 to 20 MHz	1 no.
6.	Multimeter		1 no.
7.	Breadboard		1 no.
8.	Connecting wires		

#### PRINCIPLE

Emitter follower is the popular name for common collector amplifier. Its voltage gain is approximately unity (without  $R_L$  voltage gain is unity). It has high input impedance and low output impedance. Thus emitter follower has less loading effect and is suitable for impedance matching.

Since collector is directly connected to dc source, it appears to be grounded for ac signal. Output is taken from the emitter terminal. The output voltage is in phase and is equal to the input



signal. Since the amplitude and phase of the output (emitter) follows the input (base), the circuit is called emitter follower. In this circuit voltage divider biasing is used for base bias.  $R_E$  acts as the load for signal at the output circuit.  $R_E$  also provides a negative feedback in the circuit.

## PROCEDURE

- 1) Test the components
- 2) Assemble the circuit
- 3) Measure the dc condition using multimeter and verify whether the transistor is in active region
- 4) Apply 1Vpp, 1 KHz sinusoidal signal as input
- 5) Observe the voltages at input point ( $V_{in}$ ), at base, at emitter and at the output point ( $V_o$ ) without  $R_L$
- 6) Measure the amplitudes and dc levels
- 7) Plot the waveforms
- 8) Observe and measure  $V_o$  with  $R_L = 10\text{ K}\Omega$  and  $R_L = 1\text{ K}\Omega$
- 9) Calculate the voltage gain for the above three conditions of  $R_L$

## CIRCUIT DIAGRAM

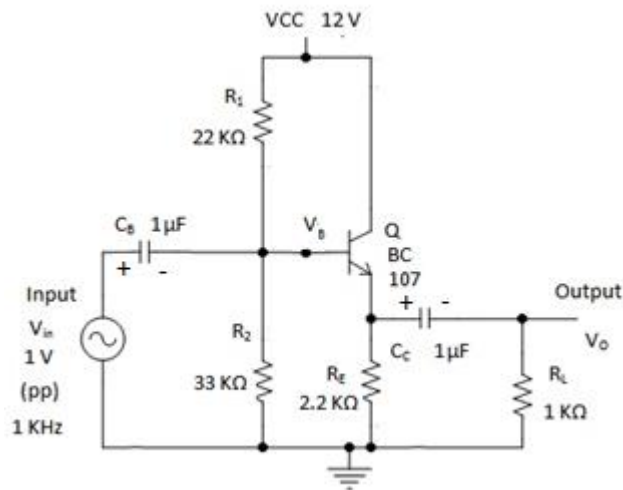

## OBSERVATIONS

1. DC Condition (multimeter)

$$V_{CC} =$$

$$V_{CE} =$$

$$V_{BE} =$$

*Note : At proper biased condition,  $V_{BE}$  should be 0.6V to 0.7V,  $V_{CE}$  should be approximately half of  $V_{CC}$*



## 2. Input Output waveforms

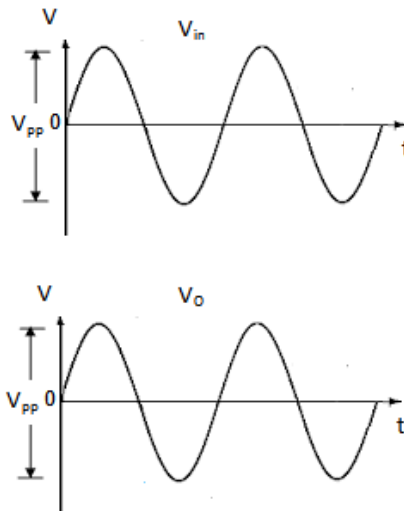

$V_{in} = 1V$  (pp), 1 KHz, without  $R_L$

## 3. Voltage gain

(i) Without load ( $R_L = \infty$ )

$$V_O = 1V$$
$$\text{Gain} = \frac{V_O}{V_{in}} = 1$$

(ii) Voltage gain with 10 K $\Omega$  load

$$V_O =$$
$$\text{Gain} =$$

(iii) Voltage gain with 1 K $\Omega$  load

$$V_O =$$
$$\text{Gain} =$$

**RESULT:**

**INFERENCE:**



<https://mail.gptcthirurangadi.in>





## Experiment No. 6

### SINGLE STAGE TUNED AMPLIFIER

#### AIM

To construct a single stage tuned amplifier circuit and

- (i) Plot its frequency response
- (ii) Measure its peak gain and bandwidth

#### OBJECTIVES

On completion of the experiment students will be able to

- ❖ Assemble a tuned amplifier
- ❖ Measure the DC conditions
- ❖ Tune the amplifier for a suitable resonant frequency
- ❖ Calculate the gain, resonant frequency and bandwidth
- ❖ Understand the characteristics of a tuned amplifier

#### EQUIPMENTS / COMPONENTS

Sl. no.	Name and Specification	Quantity
1.	Resistor 68 K $\Omega$	1 no.
	100 K $\Omega$	1 no.
	5.6 K $\Omega$	1 no.
2.	Capacitor 1 $\mu$ F	2 nos.
	10 $\mu$ F	1 no.
3.	Transistor BC 495 BC 495	1 no.
4.	IFT	1 no.
5.	Function generator 0 to 1 MHz	1 no.
6.	Oscilloscope 0 to 20 MHz	1 no.
7.	Multimeter	1 no.
8.	Breadboard	1 no.
9.	Connecting wires	

#### PRINCIPLE

Tuned voltage amplifier amplifies the signals of desired frequency and rejects all other frequencies. The frequencies of amplification are determined by a parallel resonance circuit. A parallel resonance (LC) circuit shows high impedance at the resonant frequency  $f_r = \frac{1}{2\pi\sqrt{LC}}$ . The gain



of the amplifier is maximum at centre frequency because the gain is directly proportional to the impedance at the collector. On either side of the resonant frequency, voltage gain falls. The selectivity of the circuit  $Q$  is given by the expression,

$$Q = \frac{\text{Resonant frequency}}{\text{Bandwidth}}$$

The ability of the tuned circuit to amplify a narrow band of frequencies makes it ideal for amplifying radio and TV signals. They are widely used as IF (Intermediate Frequency) amplifiers in radio and TV receivers. The IF Transformer used in this circuit is of AM radio receivers. It uses 455 KHz as standard IF. However resonant frequency can be varied beyond and above 455 KHz by adjusting the core of the transformer.

## PROCEDURE

1. Test the components
2. Assemble the circuit on bread board
3. Check the DC biasing conditions of the transistor
4. Set 100mv sinusoidal signal as input
5. Vary the frequency of input from 400Khz to 500Khz in suitable steps
6. Measure the output voltage in each step
7. Calculate the gain in each step
8. Plot the frequency response in a graph sheet
9. Calculate resonant frequency, Bandwidth and  $Q$  factor

## CIRCUIT DIAGRAM

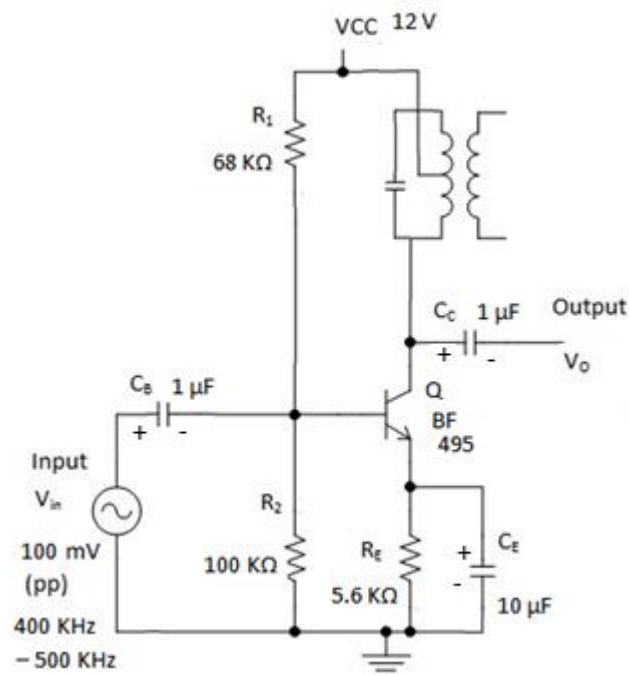



## OBSERVATIONS

### 1. DC conditions

$$V_{CC} =$$

$$V_{BE} =$$

$$V_{CE} =$$

### 2. Input and output waveforms

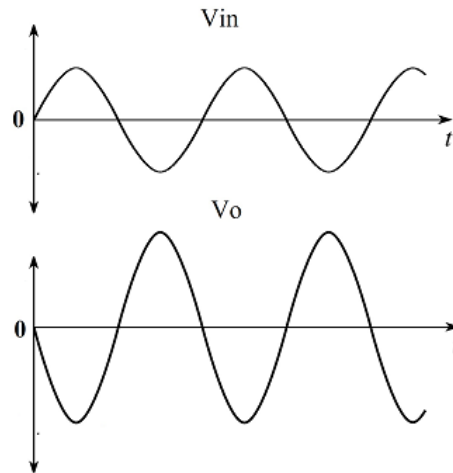

### 3. Frequency response

$$V_{in} = 100 \text{ mV (pp)}, f = 400 \text{ KHz to } 500 \text{ KHz}$$

Frequency (f) in KHz	Log f	$V_O$ in Volt	Gain = $\frac{V_O}{V_{in}}$	Gain in dB $20 \log (\text{Gain})$

Resonant frequency,  $f_r =$

$$f_H =$$

$$f_L =$$



$$\text{Bandwidth} = f_H - f_L =$$

$$\text{Q factor} = \frac{f_r}{\text{bandwidth}} =$$

**RESULT:**

**INFERENCE:**



## Experiment No. 7

### RC PHASE SHIFT OSCILLATOR

#### AIM

To setup RC phase shiftoscillator for 1 KHz and

- (i) plot the output waveform
- (ii) measure the frequency of oscillation

#### OBJECTIVES

On completion of the experiment students will be able to construct an RC phase shift oscillator for a given frequency

#### EQUIPMENTS / COMPONENTS

Sl. no.	Name and specification	Quantity
1.	Capacitor	0.01 $\mu\text{F}$
		1 $\mu\text{F}$
		22 $\mu\text{F}$
2.	Resistor	470 $\Omega$
		1.8 K $\Omega$
		4.7 K $\Omega$
		10 K $\Omega$
		47 K $\Omega$
3.	Variable resistor – Potentiometer (lin)	10 K $\Omega$
4.	Transistor	BC 548
5.	Power supply	12 V
6.	Oscilloscope	0 to 20 MHz
7.	Multimeter	
8.	Breadboard	
9.	Connecting wires	

#### PRINCIPLE

An oscillator is an electronic circuit for generating ac signal voltage with a dc supply as the only input requirement. The frequency of the generated signal is decided by the circuit elements. An



oscillator requires an amplifier a frequency selective network and positive feedback from the output to the input. The Barkhausen criteria for sustained oscillator is  $A\beta = 1$ , where  $A$  is gain of the amplifier and  $\beta$  is the feedback factor.

If common emitter amplifier is used with resistive collector load, there is an  $180^\circ$  phase shift between input and output. The feedback network introduces an additional  $180^\circ$  phase shift at a particular frequency. The three section RC network offers  $180^\circ$  phase shift and the  $\beta$  of  $\frac{1}{29}$ . Hence for unity gain feedback, the gain of the amplifier should be 29. The phase shift oscillator is particularly useful as audio frequency generator. The frequency of oscillation is given by  $\frac{1}{2\pi\sqrt{6}RC}$ .

## PROCEDURE

- 1) Test the components
- 2) Assemble the amplifier part of the circuit in a breadboard
- 3) Connect the feedback network
- 4) Connect the output of the circuit to an oscilloscope
- 5) Adjust the  $10\text{ K}\Omega$  pot and observe the output
- 6) Measure the frequency and amplitude of the output
- 7) Plot output waveform

## CIRCUIT DIAGRAM

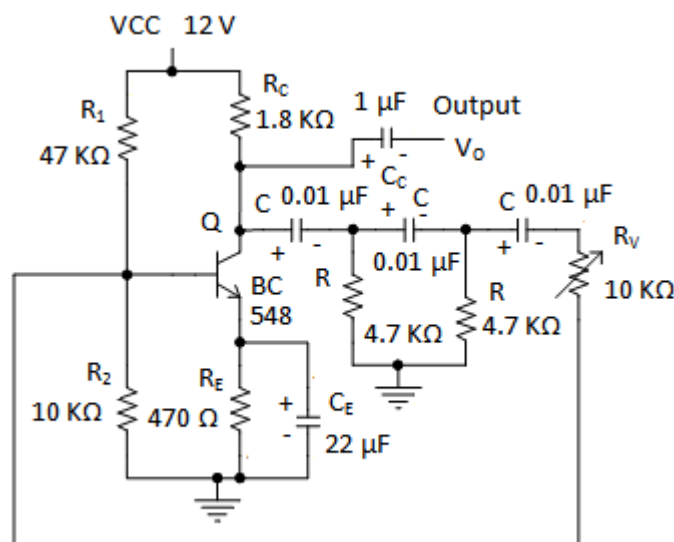

From the given component values, the frequency of oscillation

$$f = \frac{1}{2\pi\sqrt{6}RC} = \frac{1}{2\pi\sqrt{6} \times 4.7 \times 10^3 \times 0.01 \times 10^{-6}} =$$

## OBSERVATIONS

1. DC conditions of amplifier section

(i)  $V_{CC} =$



- (ii)  $V_{BE} =$
- (iii)  $V_{CE} =$

2. Output waveform

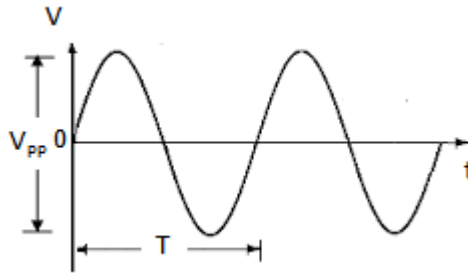

Time period,  $T =$

Frequency,  $f = \frac{1}{T} =$

**RESULT:**

**INFERENCE:**



<https://mail.gptcthirurangadi.in>





## Experiment No. 8

### WEIN BRIDGE OSCILLATOR

#### AIM

To construct a Wein bridge oscillator and

- (i) plot the output wave form
- (ii) measure the frequency of oscillation

#### OBJECTIVES

On completion of the experiment students will be able to

- ❖ assemble a Wein bridge oscillator circuit
- ❖ measure the frequency of oscillation
- ❖ understand the necessary conditions for oscillation

#### EQUIPMENTS / COMPONENTS

Sl. no.	Name and Specification	Quantity	
1.	Resistors	680 $\Omega$	2 nos.
		2.2 K $\Omega$	2 nos.
		4.7 K $\Omega$	2 nos.
		10 K $\Omega$	2 nos.
		47 K $\Omega$	2 nos.
2.	Variable resistors (Potentiometer – lin)	4.7 K $\Omega$	1 no.
3.	Capacitor	0.033 $\mu$ F	2 nos.
		1 $\mu$ F	2 nos.
4.	Transistor	BC 107	2 nos.
5.	Power supply	12 V DC	1 no.
6.	Oscilloscope	0 to 20 MHz	1 no.
7.	Multimeter		1 no.
8.	Breadboard		1 no.
9.	Connecting wires		

## PRINCIPLE

In Wein bridge oscillator the frequency determining network is balanced Weinbridge comprising resistors and capacitor. This is an RC oscillator. The attenuation of the bridge is  $\frac{1}{3}$  at resonant frequency. Therefore the amplifier stage should provide a gain of 3 and make loop gain unity. The gain of two stage amplifier circuit is made slightly greater than 3 to compensate the losses also. Frequency of oscillation  $f = \frac{1}{2\pi RC}$ .

## PROCEDURE

1. Test the components
2. Assemble the circuit in bread board
3. Switch ON the power supply
4. Measure and verify the DC biasing conditions of the transistor
5. Connect the output to oscilloscope
6. Adjust the potentiometer to get a desired frequency if necessary
7. Observe and measure the amplitude and time period of the output
8. Calculate the frequency of oscillation

## CIRCUIT DIAGRAM

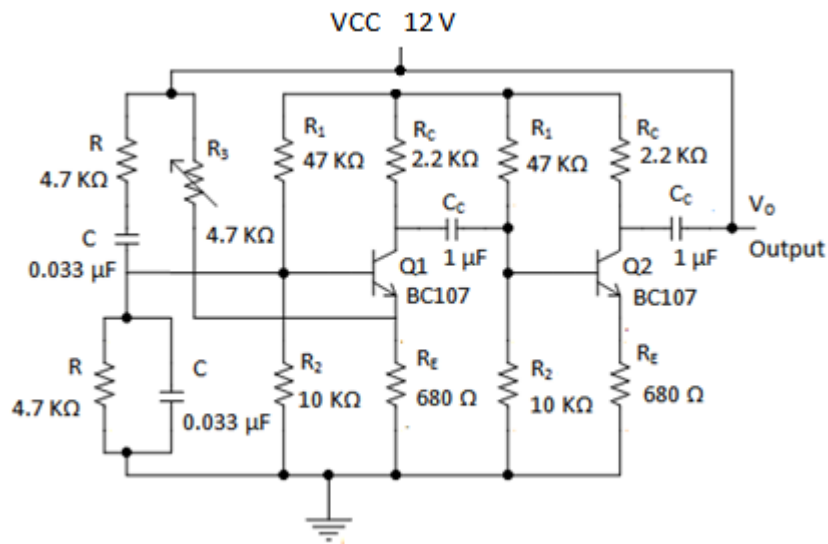

## OBSERVATIONS

$$\text{Theoretical value, } f = \frac{1}{2\pi RC} = f = \frac{1}{2\pi \times 4.7 \times 10^3 \times 0.033 \times 10^{-6}}$$

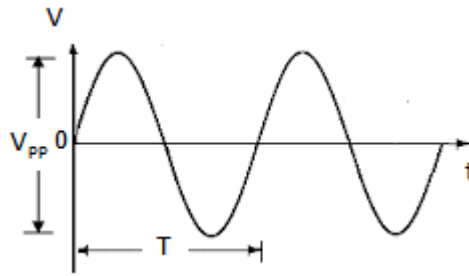

$$T =$$

$$f = \frac{1}{T} =$$

**RESULT:**

**INFERENCE:**



<https://mail.gptcthirurangadi.in>



## Experiment No. 9

### HARTLEY OSCILLATOR

#### AIM

To set up a Hartley oscillator and

- (i) Plot the output waveform
- (ii) Measure the frequency of oscillation

#### OBJECTIVES

On completion of the experiment students will be able to

- ❖ Assemble Hartley oscillator
- ❖ Test and verify the DC conditions of the circuit
- ❖ Tune a resonant circuit for a desired frequency

#### EQUIPMENTS / COMPONENTS

Sl. no.	Name and Specification	Quantity	
1.	Resistors	560 $\Omega$	1 no.
		1.8 K $\Omega$	1 no.
		10 K $\Omega$	1 no.
		47 K $\Omega$	1 no.
2.	Capacitor	1 $\mu$ F	2 nos.
3.	Transistor	BC 548	1 no.
4.	IFT		1 no.
5.	Oscilloscope	0 to 20 MHz	1 no.
6.	Multimeter		1 no.
7.	Breadboard		1 no.
8.	Connecting wires		

#### PRINCIPLE

Hartley oscillator is an LC oscillator. It has LC tank circuit for frequency selection. LC oscillators are preferred for higher frequencies. Voltage divider bias is used for the amplifier in CE configuration. Amplifier section provides 180° phase shift. The tank circuit provides another 180° phase shift to satisfy Barkhausen criteria.  $R_E$  is bypassed by  $C_E$  to prevent ac signal feedback and thus to improve the gain of the amplifier.



Frequency of oscillation is determined by the resonant circuit consisting of capacitor C and inductors  $L_1$  and  $L_2$ . It is given by  $f = \frac{1}{2\pi\sqrt{L_{eq}C}}$  Hz. Where  $L_{eq} = L_1 + L_2$ , since  $L_1$  is in series with  $L_2$ .

The output voltage appears across  $L_1$  and feedback voltage appears across  $L_2$ . So the feedback factor of the oscillator is given by  $\beta = \frac{L_2}{L_1}$ . This means that the gain of the amplifier section is  $A = \frac{L_1}{L_2}$ .

## PROCEDURE

1. Test the components
2. Assemble the circuit on bread board
3. Switch ON the power supply
4. Measure and verify the DC biasing conditions of the transistor
5. Connect the output to oscilloscope
6. Observe and measure the amplitude and time period of the output
7. Calculate the frequency of oscillation
8. Adjust the core of IFT to get a desired frequency if necessary
9. Switch off the power supply and dismantle the circuit

## CIRCUIT DIAGRAM

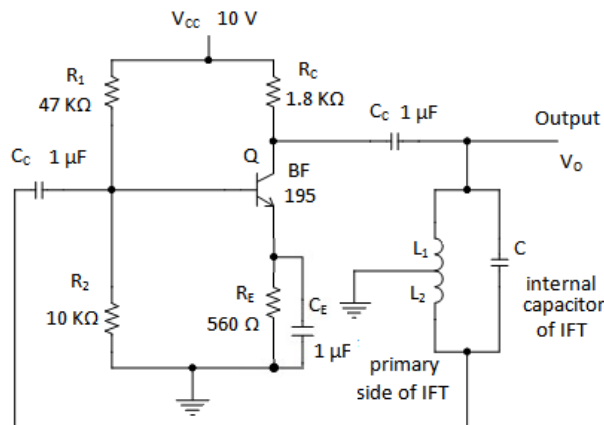

## OBSERVATIONS

1. DC condition

VCC =  
VBE =  
VCE =



2. Output waveform

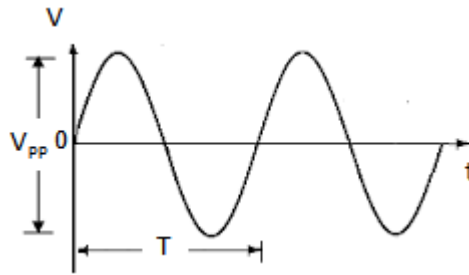

**RESULT:**

**INFERENCE:**



<https://mail.gptcthirurangadi.in>





## Experiment No. 10

### COLPITT'S OSCILLATOR

#### AIM

To set up a Colpitt's oscillator and

- (i) Plot the output waveform
- (ii) Measure the frequency of oscillation

#### OBJECTIVES

On completion of the experiment students will be able to

- ❖ Assemble Colpitt's oscillator
- ❖ Test and verify the DC conditions of the circuit
- ❖ Tune a resonant circuit for a desired frequency

#### EQUIPMENTS / COMPONENTS

Sl. no.	Name and Specification	Quantity
1.	Resistors 560 $\Omega$	1 no.
	1.8 K $\Omega$	1 no.
	10 K $\Omega$	1 no.
	47 K $\Omega$	1 no.
2.	Capacitor 0.001 $\mu$ F	2 nos.
	1 $\mu$ F	1 no.
	10 $\mu$ F	1 no.
3.	Transistor BC 548	1 no.
4.	IFT	1 no.
5.	Power supply 10 V DC	1 no.
5.	Oscilloscope 0 to 20 MHz	1 no.
6.	Multimeter	1 no.
7.	Breadboard	1 no.
8.	Connecting wires	



## PRINCIPLE

Colpitt's oscillator is also an LC oscillator. The tank circuit is made up of  $C_1$ ,  $C_2$  and  $L$ .  $R_1$ ,  $R_2$  and  $R_E$  provide self bias for the transistor. Capacitors  $C_1$  and  $C_2$  act as an ac voltage divider and produce  $180^\circ$  phase shift. A further phase shift of  $180^\circ$  is provided by the CE amplifier. In this way proper feedback is supplied to produce continuous undamped oscillations.

The frequency of oscillation is given by the expression  $f = \frac{1}{2\pi\sqrt{LC_{eq}}}$  where  $C_{eq} = \frac{C_1 C_2}{C_1 + C_2}$ , because  $C_1$  is in series with  $C_2$ . The output voltage appears across  $C_1$  and the feedback voltage appears across  $C_2$ . So the feedback factor is given by  $\beta = \frac{C_1}{C_2}$ . Gain of the amplifier section should be  $A \geq \frac{C_2}{C_1}$  for sustained oscillation

## PROCEDURE

1. Test the components
2. Assemble the circuit on bread board
3. Switch ON the power supply
4. Measure and verify the DC biasing conditions of the transistor
5. Connect the output to oscilloscope
6. Observe and measure the amplitude and time period of the output
7. Calculate the frequency of oscillation
8. Adjust the core of IFT to get a desired frequency if necessary
9. Switch off the power supply and dismantle the circuit

## CIRCUIT DIAGRAM

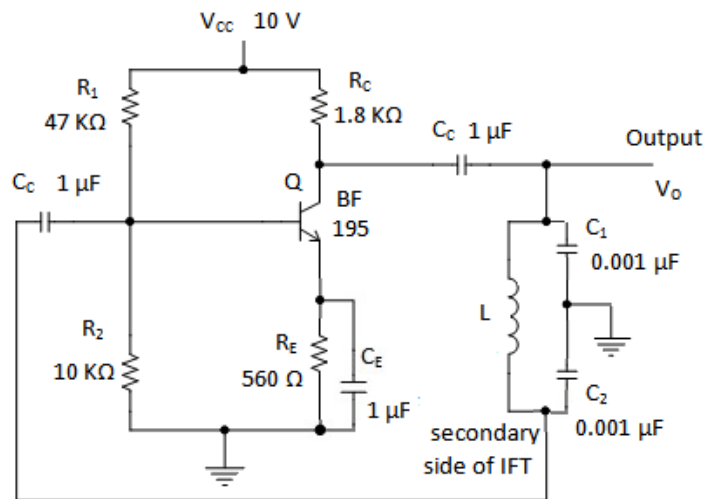

*Note : put a load resistance of 47 KΩ if necessary*



## OBSERVATIONS

1. DC condition

VCC =

VBE =

VCE =

2. Output waveform

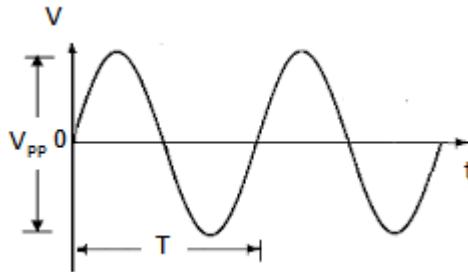

**RESULT:**

**INFERENCE:**



<https://mail.gptcthirurangadi.in>



## Experiment No. 11

### ASTABLE MULTIVIBRATOR

#### AIM

To construct a transistor astablemultivibrator circuit for 1 KHz and

- (i) plot the collector and base waveforms
- (ii) measure the frequency of oscillation

#### OBJECTIVES

On completion of the experiment students will be able to

- (i) construct an astablemultivibrator for a given frequency
- (ii) construct an LED flasher circuit
- (iii) calculate the period and hence the frequency of an astablemultivibrator from its component values

#### EQUIPMENTS / COMPONENTS

Sl. no.	Name and specification	Quantity
1.	Capacitor            0.01 $\mu$ F	2 nos.
2.	Resistor                2.2 K $\Omega$	2 nos.
	75 K $\Omega$	2 nos.
3.	Transistor            BC 548	2 nos.
4.	Power supply        5 V	1 no.
5.	Oscilloscope        0 to 20 MHz	1 no.
6.	Multimeter	1 no.
7.	Breadboard	1 no.
8.	Connecting wires	

#### PRINCIPLE

Astablemultivibrator is also called free running multivibrator and is used as a square wave oscillator. The transistors in the circuit do not have stable state. i.e. when  $V_{cc}$  is given, one transistor turns ON (goes to saturation region) and the other turns OFF (goes to cut off region). After sometime (determined by charging and discharging of the two capacitors in the circuit), the ON transistor is turns OFF and the OFF transistor turns ON. This cycle repeats as long as the supply is given.

When the power supply is turned ON, one of the transistors is ON and the other is OFF due to transistor mismatch. When Q1 is ON, Q2 is OFF due to the cross coupling. Collector of Q1 is at  $V_{sat}$  ( $\approx 0$ ) and collector of Q2 is at  $V_{cc}$ . Now the previously charged capacitor (when Q2 is ON) discharges through Q1 and after discharging completely it starts charging towards  $V_{cc}$ . But as one side of the capacitor reaches 0.7V, Q2 turns ON and its collector voltage falls to approximately 0V ( $V_{cesat}$ ). This sudden change is coupled to the base of Q1 via C2. Thus Q1 turns OFF and the collector of Q1 reaches  $V_{cc}$ . Then C2 (which was charged when Q1 was ON), discharges through Q2 and when other side of C2 reaches 0.7V, Q1 turns ON. These actions continue. Thus OFF time of Q2 is determined by the values of R1 and C1 ( $T_{OFFQ2} = 0.693 R_1 C_1$ ) while the OFF period of Q1 is determined by the values of R2 and C2 ( $T_{OFFQ1} = 0.693 R_2 C_2$ ). If  $R_1 = R_2 = R$  and  $C_1 = C_2 = C$ , we get a square wave from collector of the transistors. The time period of the square wave,  $T = 0.693 R_1 C_1 + 0.693 R_2 C_2 = 1.38 R C$  and  $f = \frac{1}{T}$ .

The second circuit is designed to get large ON and OFF periods for the transistors to visualize the ON and OFF action of transistors. For this LEDs are connected at the collector of the transistors. Here large value of C (10 $\mu$ F) is used to get T in seconds.

## PROCEDURE

- 1) Test the components
- 2) Assemble the circuit in a breadboard
- 3) Switch ON the power supply
- 4) Connect the outputs of the circuit to an oscilloscope
- 5) Observe the collector and base waveforms of the two transistors
- 6) Measure the frequency and amplitude of the outputs
- 7) Plot all waveforms
- 8) Assemble the second circuit and visually verify the output

## CIRCUIT DIAGRAM

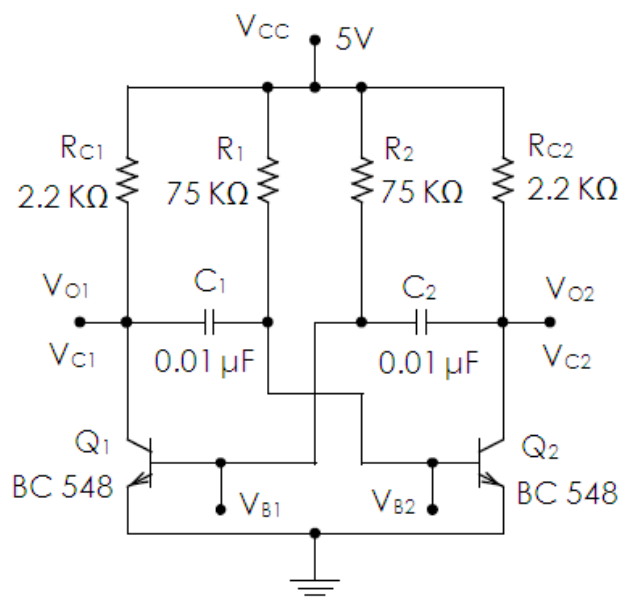

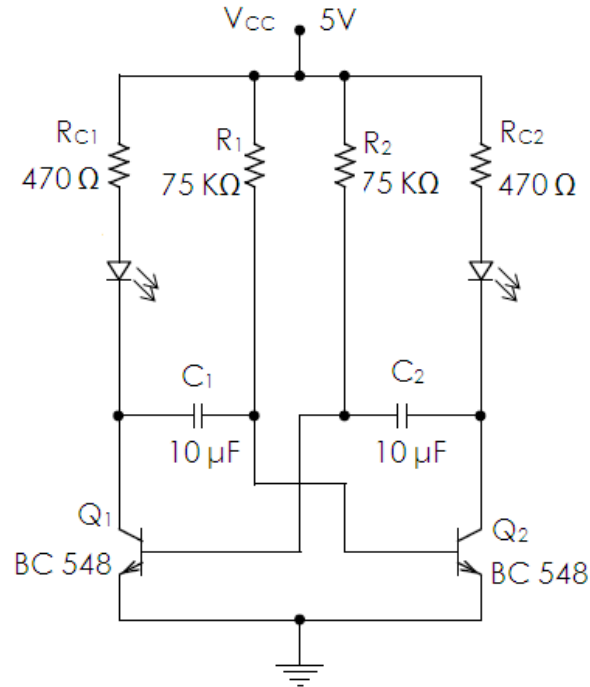

## DESIGN

1. For 1 KHz frequency

$$T_{\text{OFF}Q2} = 0.693 R C = 0.693 \times 75 \times 10^3 \times C = 0.5\text{ms}$$

$$C = 0.01\mu\text{F}$$

$$T_{\text{OFF}Q1} = 0.693 R C = 0.693 \times 75 \times 10^3 \times C = 0.5\text{ms}$$

$$C = 0.01\mu\text{F}$$

$$T = 1\text{ms}, f = \frac{1}{T} = 1 \text{ KHz}$$

2. For 2 Hz frequency

$$\text{ON / OFF time of LED} = 0.693 R C = 0.693 \times 75 \times 10^3 \times C = 0.5\text{s}$$

$$C = 10\mu\text{F}$$

## OBSERVATIONS

1. For 1 KHz frequency astable multivibrator circuit

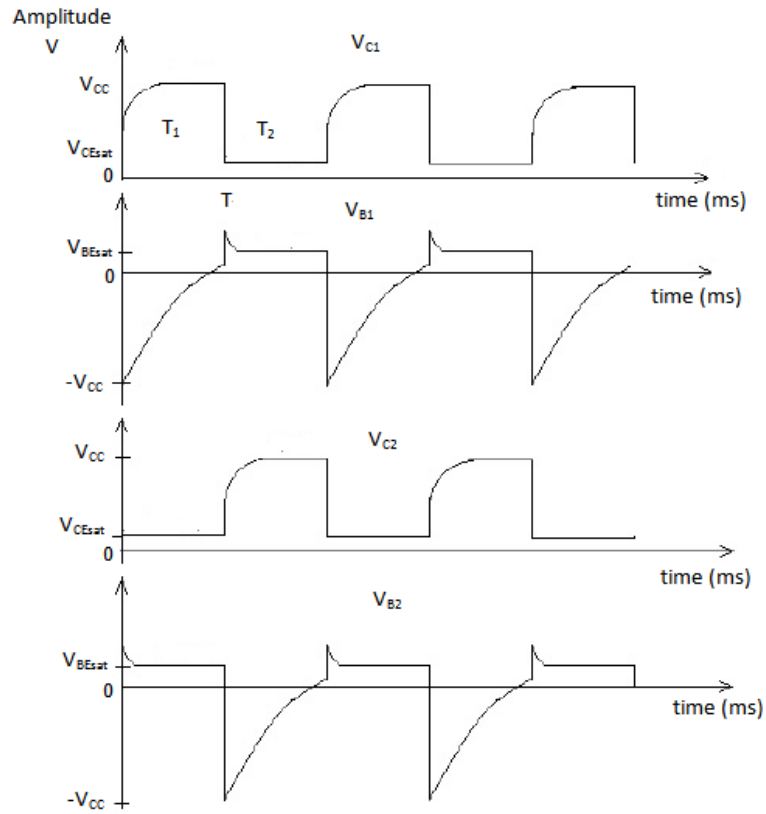

ON time of Q1,  $T_1 =$   
 OFF time of Q1,  $T_2 =$   
 Time period,  $T = T_1 + T_2 =$   
 Frequency,  $f = \frac{1}{T} =$

2. For 2 Hz frequency astable multivibrator circuit

Both LEDs turn ON and OFF with 0.5s delay

**RESULT:**

**INFERENCE:**





## Experiment No. 12

### MONOSTABLE MULTIVIBRATOR

#### AIM

To set up a transistor monostablemultivibrator circuit and

- (iii) Plot the collector and base waveforms
- (iv) Measure the period of the pulse generated

#### OBJECTIVES

On completion of the experiment students will be able to

- ❖ assemble Monostablemultivibrator circuit to generate a pulse of required time period
- ❖ calculate the width of pulse generated from the component values in the given circuit diagram
- ❖ design and assemble monostablemultivibrator circuit for large time delays and testing the same with LED

#### EQUIPMENTS / COMPONENTS

Sl. no.	Name and Specification	Quantity
1.	Resistors	4.7 K $\Omega$
		5.6 K $\Omega$
		47 K $\Omega$
		56 K $\Omega$
		150 K $\Omega$
2..	Capacitor	0.01 $\mu$ F
3.	Transistor	BC 548
4.	Diode	1N 4007
5.	Function generator	0 to 1 MHz
6.	Power supply	10 V DC
7.	Oscilloscope	0 to 20 MHz
8.	Multimeter	1 no.
9.	Breadboard	1 no.
10.	Connecting wires	



## PRINCIPLE

Monostablemultivibrators are used for generating a pulse of desired time period when a trigger voltage is applied. As the name implies the circuit has one stable state (In this circuit  $Q_1$  OFF and  $Q_2$  ON is the stable state). The external trigger forces this circuit to go to a quasi stable state and remain in that state for an amount of time determined by the discharging time of the capacitor (R and C are the timing elements).

As soon as the power supply is switched ON,  $Q_1$  goes to cut off and  $Q_2$  goes to saturation due to the biasing condition and regenerative (positive feedback) action. This is the stable state and the stable state voltages are  $V_{C1} = V_{cc}$ ,  $V_{C2} = V_{cesat}$ .

When a negative trigger is applied at the base of the ON transistor  $Q_2$ , it goes to cut off resulting its collector voltage to jump to  $V_{cc}$ . This sudden change is coupled to the base of  $Q_1$  and  $Q_1$  goes to ON state. This is the quasi stable state of the circuit. The duration of the quasi stable state is determined by the discharging of C, that is the time constant RC. After this time both the transistors go to the stable state again and they remain in that state until the next trigger input is received by  $Q_2$ . The time duration of the quasi stable state is given by  $T = 0.693 RC$

In the second circuit large time constant is used to get time delay in seconds in order to visualize using LED.

## PROCEDURE

1. Check the given components
2. Assemble the circuit on a bread board
3. Switch ON the power supply
4. Connect the output to oscilloscope
5. Observe the waveforms at relevant points in the circuit
6. Measure the amplitudes and time periods and plot these waveforms
7. Assemble the second circuit and visually verify the output

## CIRCUIT DIAGRAM

1. Observe output waveform on oscilloscope

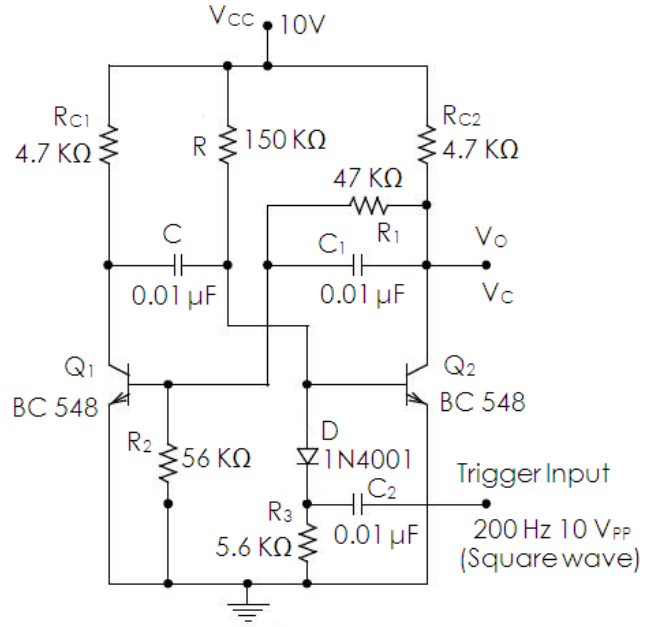

2. Verify output visually using LED

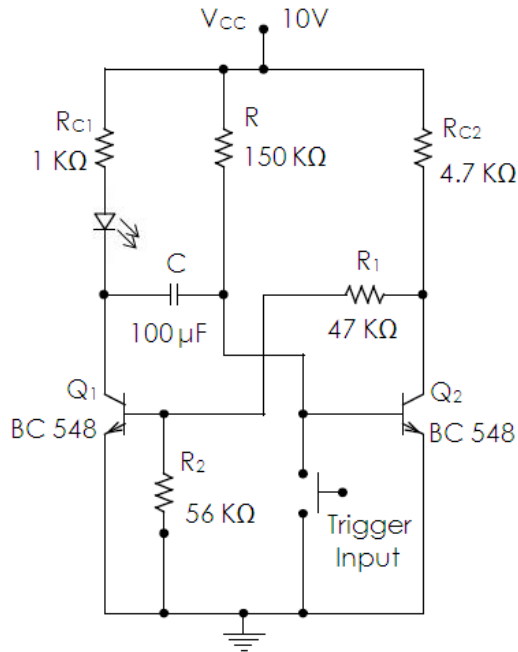



## OBSERVATIONS

Waveforms at various points in the circuit

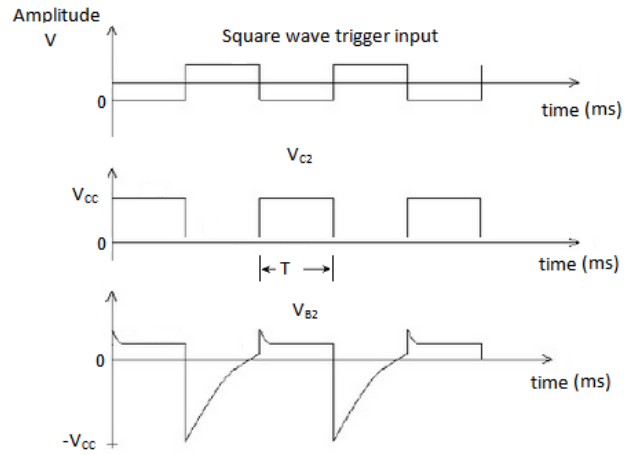

**RESULT:**

**INFERENCE:**



## Experiment No. 13

### SCHMITT TRIGGER

#### AIM

To setup a Schmitt trigger circuit using BJT

- (i) plot the input and output waveforms
- (ii) measure the UTP and LTP

#### OBJECTIVES

On completion of the experiment students will be able to

- (i) construct an Schmitt trigger circuit using BJT
- (ii) know the application of Schmitt trigger

#### EQUIPMENTS / COMPONENTS

Sl. no.	Name and specification	Quantity
1.	Capacitor 330 pF	1 no.
2.	Resistor 1.5 K $\Omega$	1 no.
	3.3 K $\Omega$	1 no.
	4.7 K $\Omega$	1 no.
	10K $\Omega$	1 no.
	33 K $\Omega$	1 no.
	47 K $\Omega$	1 no.
3.	Transistor BC 548	2 nos.
4.	Function generator 0 to 1 MHz	1 no.
4.	Power supply 8 V	1 no.
5.	Oscilloscope 0 to 20 MHz	1 no.
6.	Multimeter	1 no.
7.	Breadboard	1 no.
8.	Connecting wires	



## PRINCIPLE

The Schmitt trigger is an emitter coupled multivibrator with no cross coupling. It is a comparator that is used to convert a periodical random analog wave to square wave having the same frequency of the analog wave. The Schmitt trigger is called a squaring circuit.

Without any input the transistor Q1 is in cut off state and Q2 is in saturation state. The emitter current of Q2 ( $I_{E2}$ ) flows through common  $R_E$  causing a voltage drop across  $R_E (= I_{E2} \times R_E)$ . As the input voltage to Q1 reaches  $I_{E2}R_E + V_{BE1}$  (base to emitter voltage of Q1), Q1 turns ON and Q2 turns OFF. This level of input is called upper triggering point (UTP). The output of Q2 rises to  $V_{cc}$ . Now  $I_{E2}$  becomes zero and  $I_{E1}$  starts flowing through  $R_E$ . The minimum voltage required to hold transistor Q1 ON is equal to  $I_{E1}R_E + V_{BE1}$ . When the amplitude of the input sine wave becomes less than this Q1 turns OFF and Q2 turns ON. The output voltage then falls to a voltage called the lowering triggering point (LTP).

## PROCEDURE

- 1) Test the components
- 2) Assemble the circuit in a breadboard
- 3) Connect the output of function generator to input of the circuit
- 4) Connect the output of the circuit to an oscilloscope
- 5) Switch ON the power supply
- 6) Observe the input and output waveforms
- 7) Measure the UTP and LTP of the output voltage
- 8) Plot the waveforms

## CIRCUIT DIAGRAM

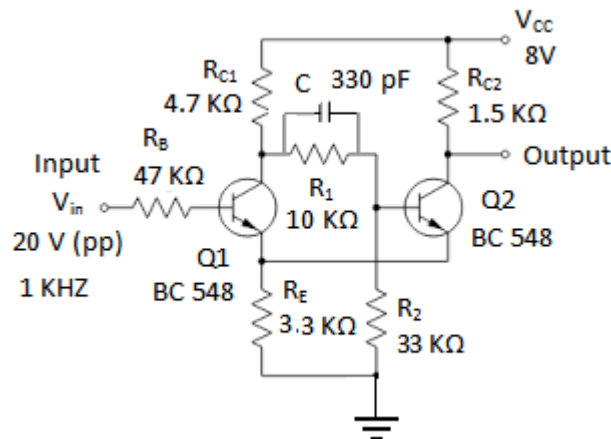

## OBSERVATIONS

Output waveforms

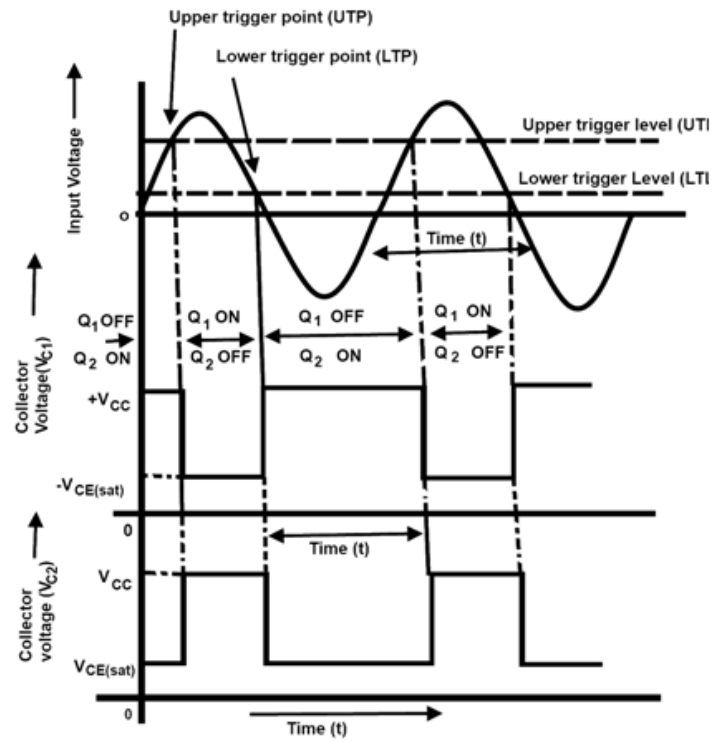

UTP =

LTP =

**RESULT:**

**INFERENCE:**



<https://mail.gptcthirurangadi.in>





## Experiment No. 14

### UJT RELAXATION OSCILLATOR

#### AIM

To construct a UJT relaxation oscillator and plot the wave forms at emitter, base1 and base2

#### OBJECTIVES

On completion of the experiment students will be able to

- ❖ assemble relaxation oscillator
- ❖ study the working of UJT and the relaxation oscillator
- ❖ understand the application of relaxation oscillator

#### EQUIPMENTS / COMPONENTS

Sl. no.	Name and Specification	Quantity
1.	Resistors 100 $\Omega$	2 nos.
	10 K $\Omega$	1 no.
2.	Capacitor 0.1 $\mu$ F	1 no.
3.	UJT 2N2646	1 no.
4.	Power supply 10 V DC	1 no.
5.	Oscilloscope 0 to 20 MHz	1 no.
6.	Multimeter	1 no.
7.	Breadboard	1 no.
8.	Connecting wires	

#### PRINCIPLE

UJT is a unipolar device. It is constructed using an N type silicon bar on which a P type silicon material is doped. It has three terminals namely base1 ( $B_1$ ), base2 ( $B_2$ ) and emitter (E). The RC circuit associated with UJT will function as a relaxation oscillator. The sharp pulse available from the circuit can be used as trigger pulse for various applications.

Once the power supply is switched ON, Capacitor C charges through R towards  $V_{BB}$ . Then the voltage across the capacitor reaches  $V_p (= \eta V_{BB} + V_d)$ , where  $\eta = 0.63$ ,  $V_d = 0.7V$ , UJT turns ON and it enters a negative resistance region. The capacitor rapidly discharges through UJT, since it then offers very low resistance. This sudden discharge develops a sharp pulse at  $B_1$ . When the capacitor voltage reaches valley voltage ( $V_v$ ) of UJT it turns OFF. This enables the capacitor to charge again and repeat the cycle.

#### PROCEDURE

- 10) Check the given components
- 11) Understand the pins of UJT
- 12) Assemble the circuit in a bred board
- 13) Connect the output of the circuit to an oscilloscope
- 14) Switch ON the power supply
- 15) Observe the wave forms at  $V_E, V_{B1}, V_{B2}$
- 16) Measure the amplitude and time periods
- 17) Plot waveforms

### CIRCUIT DIAGRAM

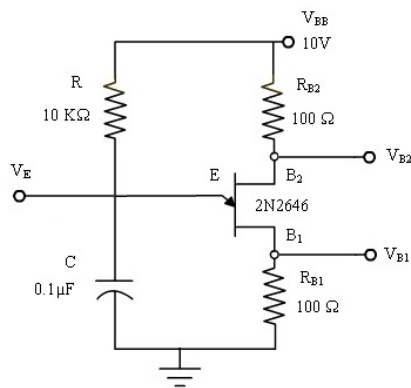

### OBSERVATIONS

Waveforms

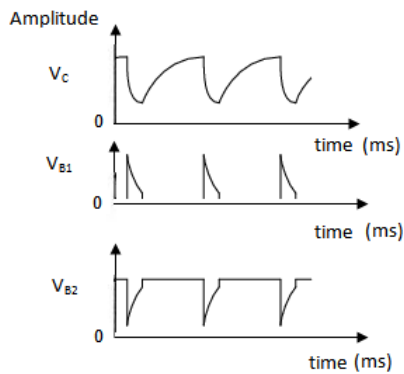

**RESULT:**

**INFERENCE:**



## Experiment No. 15

### TWO STAGE RC COUPLED AMPLIFIER

#### AIM

To construct a two stage RC coupled amplifier and measure the mid band gain

#### OBJECTIVES

On completion of the experiment, students will be able to

- ❖ assemble a two stage RC coupled amplifier
- ❖ test and verify the DC condition of the transistors
- ❖ find midband gain of the amplifier

#### EQUIPMENTS / COMPONENTS

Sl. no.	Name and Specification	Quantity	
1.	Resistors	180 $\Omega$	1 no.
		470 $\Omega$	1 no.
		680 $\Omega$	1 no.
		1 K $\Omega$	1 no.
		2.2 K $\Omega$	2 nos.
		10 K $\Omega$	2 nos.
		47 K $\Omega$	2 nos.
2.	Capacitor	10 $\mu$ F	3 nos.
		22 $\mu$ F	2 nos.
3.	Transistor	BC 107	2 nos.
4.	Function generator	0 to 1 MHz	1 no.
5.	Oscilloscope	0 to 20 MHz	1 no.
6.	Power supply	12 V dc	1 no.
7.	Multimeter		1 no.
8.	Breadboard		1 no.
9.	Connecting wires		

## PRINCIPLE

To improve the parameters such as voltage gain, current gain, input impedance and output impedance etc. amplifiers are cascaded and are called multistage amplifiers. Different coupling methods are used to cascade amplifiers. RC coupling is the most popular method of coupling in voltage amplifiers. Common emitter amplifiers are cascaded to increase the voltage gain.

When two stages are cascaded the overall gain  $A = A_1 * A_2$  ( $A_{dB} = A_{1dB} + A_{2dB}$ ), where  $A_1$  and  $A_2$  are the voltage gains of first and second stages respectively.

If overall gain of the amplifier is too large, the second transistor may go to saturation or cutoff. This will clip off the signal, thus causing distortion. Therefore a negative feedback is introduced in the circuit for the first stage with an unbypassed  $R_E$  to reduce the gain.

## PROCEDURE

- 18) Check the given components
- 19) Assemble the circuit in breadboard
- 20) Switch ON the power supply
- 21) Measure and verify the DC conditions of the transistors
- 22) Give 50mV (pp), 10 KHz sinusoidal signal as input
- 23) Connect output to oscilloscope
- 24) Observe and plot the output waveforms
- 25) Find the midband gain of the amplifier

## CIRCUIT DIAGRAM

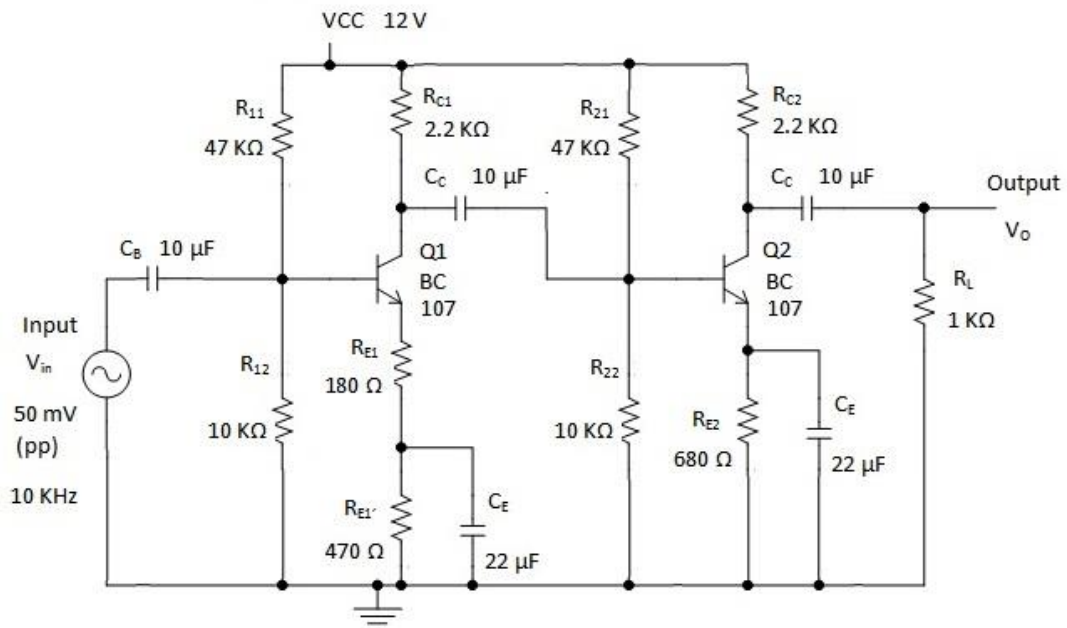



## OBSERVATIONS

1. DC conditions

Q1

Q2

$$V_{CC} =$$

$$V_{CC} =$$

$$V_{BE} =$$

$$V_{BE} =$$

$$V_{CE} =$$

$$V_{CE} =$$

2. Waveforms

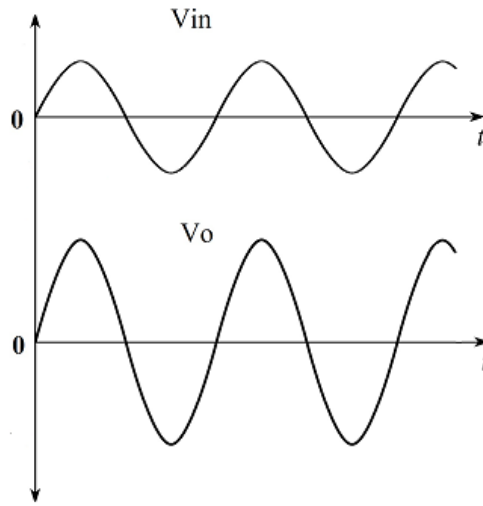

3. Calculation of gain at 10 KHz (midband gain)

$$V_{in} = 50 \text{ mV (pp)}$$

$$V_o =$$

**RESULT:**

**INFERENCE:**



<https://mail.gptcthirurangadi.in>



## Experiment No. 16

### TWO STAGE DIRECT COUPLED AMPLIFIER

#### AIM

To construct a two stage direct coupled amplifier and measure its gain

#### OBJECTIVES

On completion of the experiment students will be able to

- ❖ assemble a two stage direct coupled amplifier
- ❖ test and verify the dc conditions of the transistor
- ❖ find the gain of the amplifier

#### EQUIPMENTS / COMPONENTS

Sl. no.	Name and Specification	Quantity
1.	Resistors 100 K $\Omega$	1 no.
	22 K $\Omega$	2 nos.
	10 K $\Omega$	2 nos.
	4.7 K $\Omega$	1 no
2.	Capacitor 22 $\mu$ F	2 nos.
3.	Transistor BC 107	2 nos.
4.	Function generator 0 to 1 MHz	1 no.
5.	Oscilloscope 0 to 20 MHz	1 no.
6.	Power supply 12 V dc	1 no.
7.	Multimeter	1 no.
8.	Breadboard	1 no.
9.	Connecting wires	

#### PRINCIPLE

To amplify low frequency signals (below 10 Hz) cascaded RC coupled or transformer coupled amplifier is not suitable because the electrical size of these components become very large at extremely low frequencies. Under this circumstance, one stage is directly connected to the next stage without any interconnecting coupling devices. This type of coupling is known as direct coupling.

## PROCEDURE

- 26) Test the components
- 27) Assemble the circuit in a breadboard
- 28) Switch on the power supply and measure the dc conditions of the transistors
- 29) Connect function generator to the input of the circuit and apply a low frequency signal input
- 30) Connect an oscilloscope to the output of the circuit and observe the output waveform
- 31) Measure the amplitude of the output waveform
- 32) Calculate the gain of the amplifier

## CIRCUIT DIAGRAM

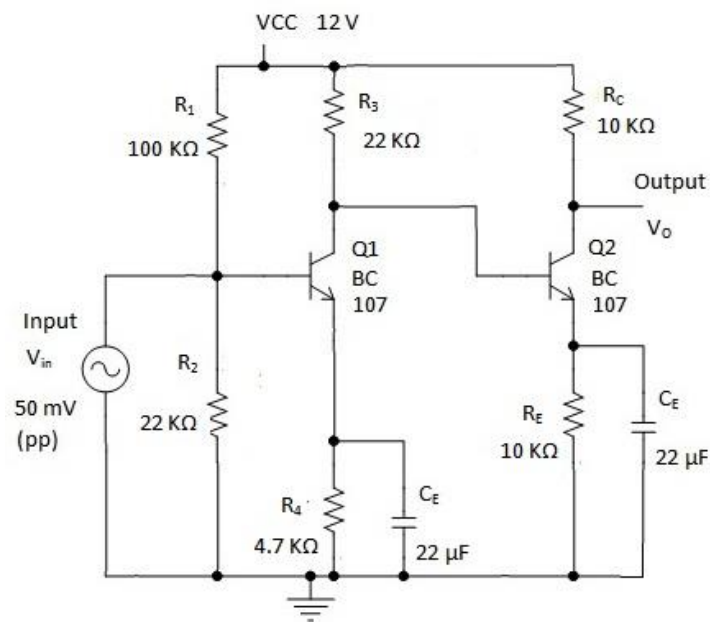

## OBSERVATIONS

1. Output waveforms

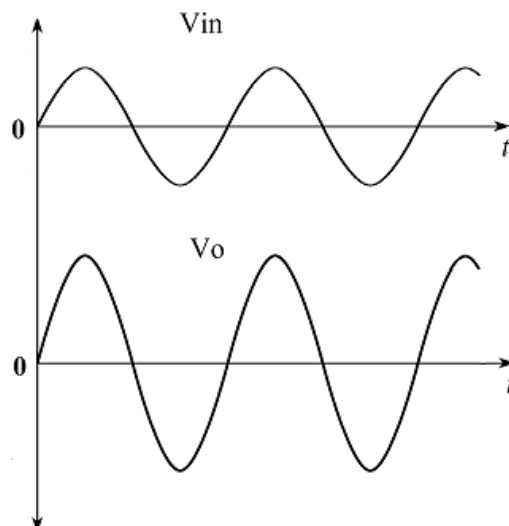





2. Calculation of gain

$$\text{Voltage gain} = \frac{V_O}{V_{in}}$$

$$V_{in} =$$

$$V_O =$$

DC conditions

Q1

Q2

$$V_{CC} =$$

$$V_{BE} =$$

$$V_{CE} =$$

$$V_{CC} =$$

$$V_{BE} =$$

$$V_{CE} =$$

**RESULT:**

**INFERENCE:**