



<https://mail.gptcthirurangadi.in>

# **LAB MANUAL**

## **LINEAR INTEGRATED CIRCUITS LAB**



## GENERAL INSTRUCTIONS

Rough record and Fair record are needed to record the experiments conducted in the laboratory. Rough records are needed to be certified immediately on completion of the experiment. Fair records are due at the beginning of the next lab period. Fair records must be submitted as neat, legible, and complete.

### INSTRUCTIONS TO STUDENTS FOR WRITING THE FAIR RECORD

In the fair record, the index page should be filled properly by writing the corresponding experiment number, experiment name, date on which it was done and the page number.

On the **right side** page of the record following has to be written:

1. **Title:** The title of the experiment should be written in the page in capital letters.
2. In the left top margin, experiment number and date should be written.
3. **Aim:** The purpose of the experiment should be written clearly.
4. **Apparatus/Tools/Equipments/Components used:** A list of the Apparatus/Tools/ Equipments /Components used for doing the experiment should be entered.
5. **Principle:** Simple working of the circuit/experimental set up/algorithm should be written.
6. **Procedure:** steps for doing the experiment and recording the readings should be briefly described(flow chart/programs in the case of computer/processor related experiments)
7. **Results:** The results of the experiment must be summarized in writing and should be fulfilling the aim.
8. **Inference:** Inference from the results is to be mentioned.

On the **Left side** page of the record following has to be recorded:

1. **Circuit/Program:** Neatly drawn circuit diagrams/experimental set up.
2. **Design:** The design of the circuit/experimental set up for selecting the components should be clearly shown if necessary.



### 3. Observations:

- i) Data should be clearly recorded using Tabular Columns.
- ii) Unit of the observed data should be clearly mentioned
- iii) Relevant calculations should be shown. If repetitive calculations are needed, only show a sample calculation and summarize the others in a table.

4. **Graphs:** Graphs can be used to present data in a form that shows the results obtained, as one or more of the parameters are varied. A graph has the advantage of presenting large amounts of data in a concise visual form. Graphs should be in a square format.

### GENERAL RULES FOR PERSONAL SAFETY

1. Always wear tight shirt/lab coat, pants and shoes inside workshops.
2. REMOVE ALL METAL JEWELLERY since rings, wrist watches or bands, necklaces, etc. make excellent electrodes in the event of accidental contact with electric power sources.
3. DO NOT MAKE CIRCUIT CHANGES without turning off the power.
4. Make sure that equipment working on electrical power are grounded properly.
5. Avoid standing on metal surfaces or wet concrete. Keep your shoes dry.
6. Never handle electrical equipment with wet skin.
7. Hot soldering irons should be rested in its holder. Never leave a hot iron unattended.
8. Avoid use of loose clothing and hair near machines and avoid running around inside lab.

### TO PROTECT EQUIPMENT AND MINIMIZE MAINTENANCE:

**DO:** 1. SET MULTIRANGE METERS to highest range before connecting to an unknown source.

2. INFORM YOUR INSTRUCTOR about faulty equipment so that it can be sent for repair.

**DO NOT:** 1. Do not MOVE EQUIPMENT around the room except under the supervision of an instructor.



## Experiment No. 1.1

### VOLTAGE FOLLOWER

**Aim:** To design and setup a voltage follower circuit with OPAMP IC 741C and observe the waveforms.

**Objectives:** After completion of this experiment, student will be able to design and setup a voltage follower using OP AMP. He/she will get ability to design a voltage follower circuit.

#### Equipments/Components:

Sl. No	Name and Specification	Quantity required
1	Dual power supply +/- 15V	1
2	Function generator (0- 1MHz)	1
3	Oscilloscope	1
4	Bread board	1
5	IC 741C	1
6	Probes and connecting wires	As required.

#### Principle:

A voltage follower (also called a unity-gain amplifier or buffer amplifier or isolation amplifier) is an op-amp circuit which has a voltage gain of 1. This means that the op amp does not provide any amplification to the signal. It is called a voltage follower because the output voltage follows the input voltage; means the output voltage is same as the input voltage. Though the gain is unity, this circuit offers high input impedance and low output impedance and hence it is used as buffer, which is used to isolate a low impedance load from a voltage source to eliminate any loading that might occur.

#### Procedure:

1. Check the components.
2. Setup the circuit on the breadboard and check the connections.
3. Switch on the power supply.
4. Give 2V<sub>pp</sub>/ 1 KHz sine wave as input.
5. Observe input and output on the two channels of the oscilloscope simultaneously.
6. Note down and draw the input and output waveforms on the graph.
7. Verify that the input and output waveforms are same in magnitude and phase.

#### Result:

#### Inference:



### Circuit Diagram

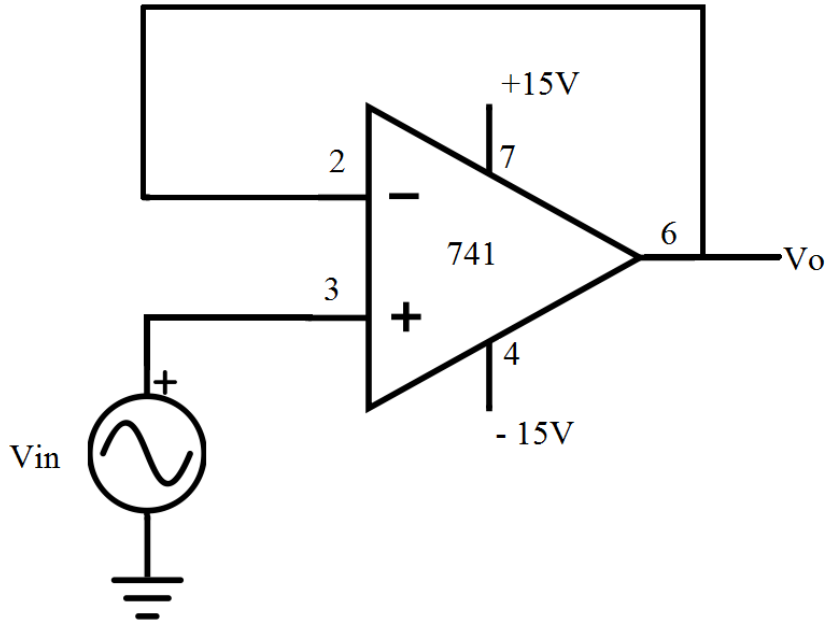

### 741 pin diagram

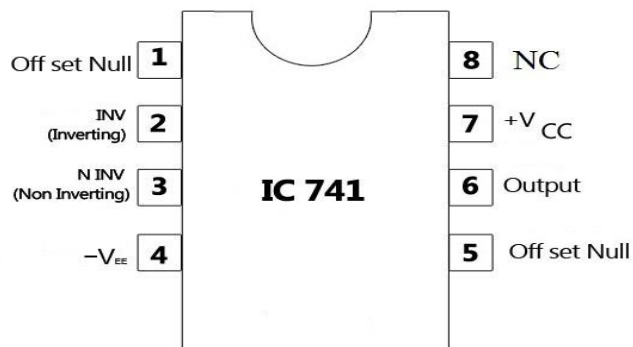

### Design:

The voltage follower is a non-inverting amplifier with unity gain.

$$A = 1 + R_f / R_i = 1$$

Or  $R_f / R_i = 0$

Therefore  $R_f = 0$

### Observation:

$V_i = ?$



<https://mail.gptcthirurangadi.in>

$V_o = ?$

Voltage gain =  $V_o / V_i = ?$ ;

Phase difference between input and output waveforms = ?

**Graph:**



## Experiment No. 1.2

### INVERTING AMPLIFIER

**Aim:** To design and setup an inverting amplifier circuit with OP AMP 741C for a gain of 10, plot the waveforms, observe the phase reversal, measure the gain.

**Objectives:** After completion of this experiment, student will be able to design and setup an inverting amplifier using OP AMP. He/she will be able to design and implement OPAMP inverting amplifier circuit.

#### Equipments/Components:

Sl.No	Name and Specification	Quantity required
1	Dual power supply +/- 15V	1
2	Function generator (0 - 1MHz)	1
3	Oscilloscope	1
4	Bread board	1
5	IC 741C	1
6	Resistors	2
7	Probes and connecting wires	As required.

#### Principle:

It is a closed loop mode application of opamp and employs negative feedback. The  $R_f$  and  $R_i$  are the feedback and input resistance of the circuit respectively. The input terminals of the opamp draws no current because of the large differential input impedance. The potential difference across the input terminals of an opamp is zero because of the large open loop gain. Due to these two conditions, the inverting terminal is at virtual ground potential. So the current flowing through  $R_i$  and  $R_f$  are the same.

$$I_i = I_f$$

That is  $V_{in}/R_i = -V_o/R_f$

Therefore  $V_o/V_{in} = A_v = -R_f/R_i$

Here the  $-Ve$  sign indicates that the output will be an amplified wave with  $180^\circ$  phase shift (inverted output). By varying the  $R_f$  or  $R_i$ , the gain of the amplifier can be varied to any desired value.

#### Procedure

1. Check the components.



2. Setup the circuit on the breadboard and check the connections.
3. Switch on the power supply.
4. Give 1 Vpp / 1 KHz sine wave as input.
5. Observe input and output on the two channels of the oscilloscope simultaneously.
6. Note down and draw the input and output waveforms on the graph.
7. Verify the input and output waveforms are out of phase.
8. Verify the obtained gain is same as designed value of gain.

**Result:**

**Inference:**

*(Note: The experiment may be repeated for different values of gain)*





**Circuit Diagram:**

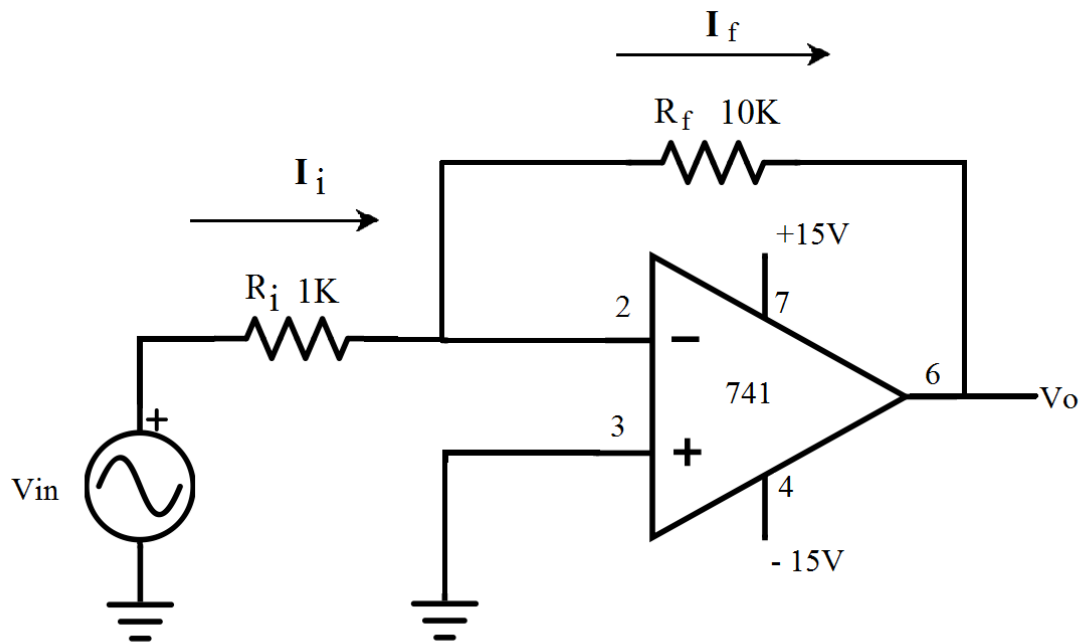

**Design:**

Gain of an inverting amplifier  $A_v = V_o/V_{in} = -R_f / R_i$

The required gain = 10,

That is  $A_v = -R_f / R_i = 10$

Let  $R_i = 1K\Omega$ , Then  $R_f = 10K\Omega$

**Observations:**

$V_{in} = 1 V_{pp}$

$V_o = ?$

Gain,  $A_v = V_o/V_{in} = ?$

Observed phase difference between the input and the output on the CRO = ?

**Graph:**



## Experiment No 1.3

### NON- INVERTING AMPLIFIER

**Aim:** To design and setup a non-inverting amplifier circuit with OPAMP IC 741C for a gain of 11, plot the waveform, observe the phase reversal, measure the gain.

**Objectives:** After completion of this experiment, student will be able to design and setup a non-inverting amplifier using OP AMP. He/she will acquire skill to design and implement OPAMP non-inverting amplifier circuit.

#### Equipments/Components:

Sl .No	Name and Specification	Quantity required
1	Dual power supply +/- 15V	1
2	Function generator (0 - 1MHz )	1
3	Oscilloscope	1
4	Bread board	1
5	IC 741C	1
6	Resistors	2
7	Probes and connecting wires	As required.

#### Principle:

It is a linear closed loop mode application of op-amp and employs negative feedback. The  $R_f$  and  $R_i$  are the feedback and input resistance of the circuit respectively. There will be no phase difference between the output and input. Hence it is called non-inverting amplifier.

$$A_v = V_o / V_{in} = 1 + R_f / R_i,$$

Here the +Ve sign indicates that the output will be an amplified wave in phase with the input. By varying the  $R_f$  or  $R_i$ , the gain of the amplifier can be varied to any desired value.

#### Procedure

1. Check the components.
2. Setup the circuit on the breadboard and check the connections.
3. Switch on the power supply.
4. Give 1 Vpp / 1 KHz sine wave as input.
5. Observe input and output on the two channels of the CRO simultaneously.
6. Note down and draw the input and output waveforms on the graph.
7. Verify the input and output waveforms are in phase.
8. Verify the obtained gain is same as designed value.

#### Result:



<https://mail.gptcthirurangadi.in>

**Inference:**

*(Note: The experiment may be repeated for different values of gain)*



### Circuit Diagram

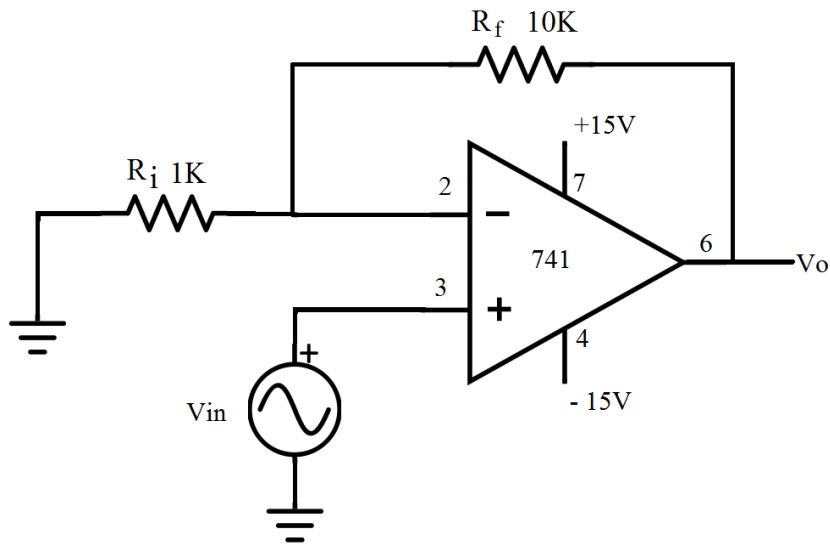

### Design:

Gain of an inverting amplifier  $A_v = V_o/V_{in} = 1 + R_f/R_i$ ,

Let the required gain be 11,

Therefore  $A_v = 1 + R_f/R_i = 11$

$$R_f/R_i = 10$$

Take  $R_i = 1K\Omega$ , Then  $R_f = 10K\Omega$

### Observations:

$V_{in} = 1V_{pp}$

$V_o = ?$

Gain  $A_v = V_o/V_{in} = ?$

Observed phase difference between the input and the output on the CRO = ?

### Graph:



## Experiment No 2.1

### SUMMING AMPLIFIER

**Aim:** To design and setup a summing amplifier circuit with OP AMP 741C for a gain of 2 and verify the output.

**Objectives:** After completion of this experiment, student will be able to design and setup a summing amplifier using OP AMP.

#### Equipments/Components:

Sl .No	Name and Specification	Quantity required
1	Dual power supply +/- 15V	1
2	DC power source 1.5V	2
3	Function generator (0- 1MHz)	1
4	Oscilloscope	1
5	Bread board	1
6	IC 741C	1
7	Resistor	3
8	Probes and connecting wires	As required.

#### Principle:

Op-amp can be used to design a circuit whose output is the sum of several input signals. Such a circuit is called a summing amplifier or an adder. Summing amplifier can be classified as inverting & non-inverting summer depending on the input applied to inverting & non-inverting terminals respectively. Circuit Diagram shows an inverting summing amplifier with 2 inputs. Here the output will be amplified version of the sum of the two input voltages with 180<sup>0</sup> phase reversal.

$$V_o = - ( R_f/ R_i)(V_1+V_2)$$

#### Procedure

1. Check the components.
2. Setup the circuit on the breadboard and check the connections.
3. Switch on the power supply.
4. Give  $V_1=V_2= +1.5V$  DC with polarity as shown in fig.1.
5. Make sure that the CRO selector is in the D.C. coupling position.
6. Observe input and output on two channels of the oscilloscope simultaneously.
7. Note down and draw the input and output waveforms on the graph.
8. Verify that the output voltage is -6VDC
9. Repeat the procedure with  $V_1=1V_{pp} / 1$  KHz sine wave and  $V_2= +1.5V_{dc}$  as shown in fig2.



10. Verify the output .

**Result:**

**Inference:**

*(Note: The experiment may be repeated for different values of gain)*

**Circuit Diagram**

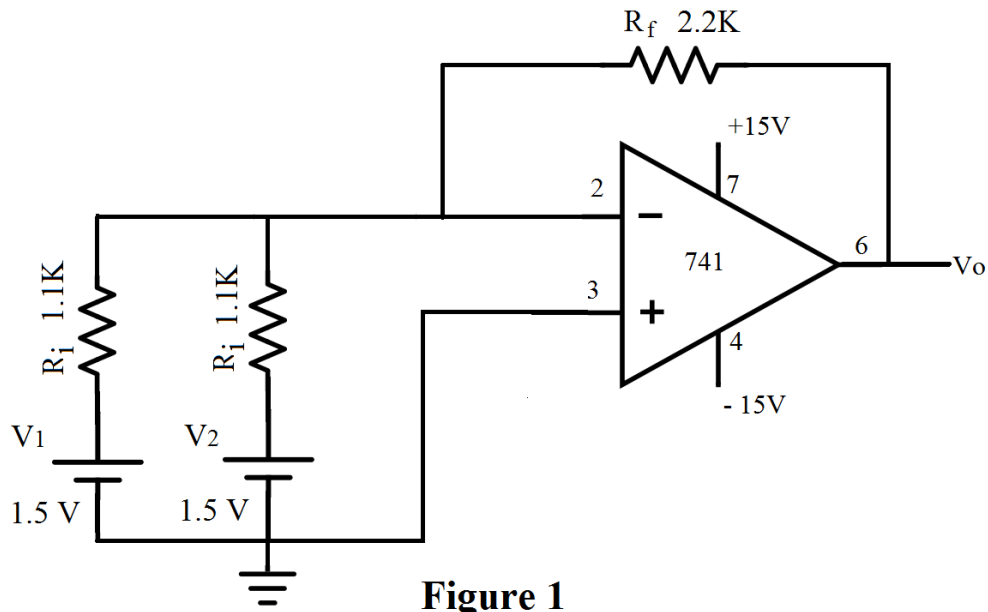

**Figure 1**

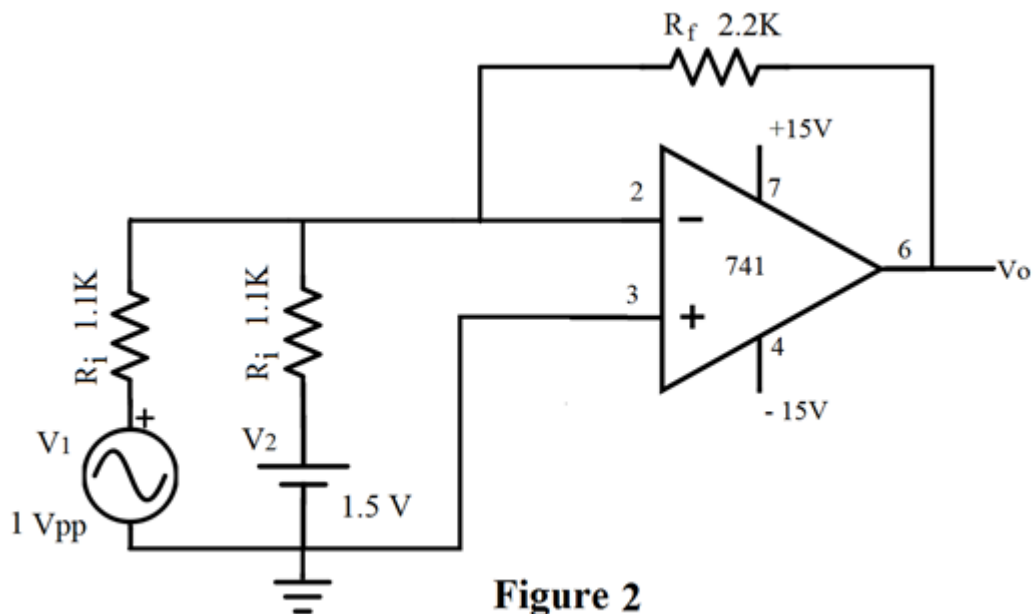

**Figure 2**

**Design:**

The output voltage of an inverting summing amplifier is given by  $V_o = -(R_f/R_i)(V_1+V_2)$

Let  $R_i = 1.1K\Omega$



Then  $R_f = 2.2K\Omega$

Then  $V_o = -2(V_1+V_2)$

**Observations:**

Part1:

$V_1 = 1.5$  DC

$V_2 = 1.5$  DC

Then  $V_o = ?$

Part 2:

$V_1 = 1V_{pp}$  sine wave

$V_2 = 1.5$  DC

Then  $V_o = ?$

**Graph:**





## Experiment No 2.2

### DIFFERENCE AMPLIFIER

**Aim:** To design and setup a difference amplifier circuit with OPAMP IC 741C for a gain of 2 and verify the output.

**Objectives:** After completion of this experiment, student will be able to design and setup a difference amplifier using OP AMP.

#### Equipments/Components:

Sl. No	Name and Specification	Quantity required
1	Dual power supply +/- 15V	1
2	DC power source 1.5V	1
3	Function generator (0-1MHz)	1
4	Oscilloscope	1
5	Bread board	1
6	IC 741C	1
7	Resistor	3
8	Probes and connecting wires	As required.

#### Principle:

A difference amplifier is a circuit that gives the amplified version of the difference of the two inputs,  $V_o = A(V_1 - V_2)$ , Where  $V_1$  and  $V_2$  are the inputs and  $A$  is the voltage gain. Here input voltage  $V_1$  is connected to non-inverting terminal and  $V_2$  to the inverting terminal. This is also called as differential amplifier. Output of a differential amplifier can be determined using super position theorem. When  $V_1 = 0$ , the circuit becomes an inverting amplifier with input  $V_2$  and the resulting output is  $V_{o2} = -R_f / R_i (V_2)$ . When  $V_2 = 0$ , the circuit become a non-inverting amplifier with input  $V_1$  and the resulting output is  $V_{o1} = R_f / R_i (V_1)$ . Therefore the resulting output according to super position theorem is

$$V_o = V_{o1} + V_{o2} = R_f / R_i (V_1 - V_2)$$

#### Procedure

1. Check the components.
2. Setup the circuit on the breadboard and check the connections.
3. Switch on the power supply.
4. Give  $V_1 = +1.5V$  DC with polarity as shown.
5. Give  $V_2 = 1V_{pp} / 1$  KHz sine wave.
6. Make sure that the oscilloscope coupling selector is in the D.C. position.
7. Observe input and output on oscilloscope simultaneously.
8. Note down and draw the input and output waveforms on the graph.



<https://mail.gptcthirurangadi.in>

**Result:**

**Inference:**

*(Note: The experiment may be repeated for different values of gain)*



### Circuit Diagram

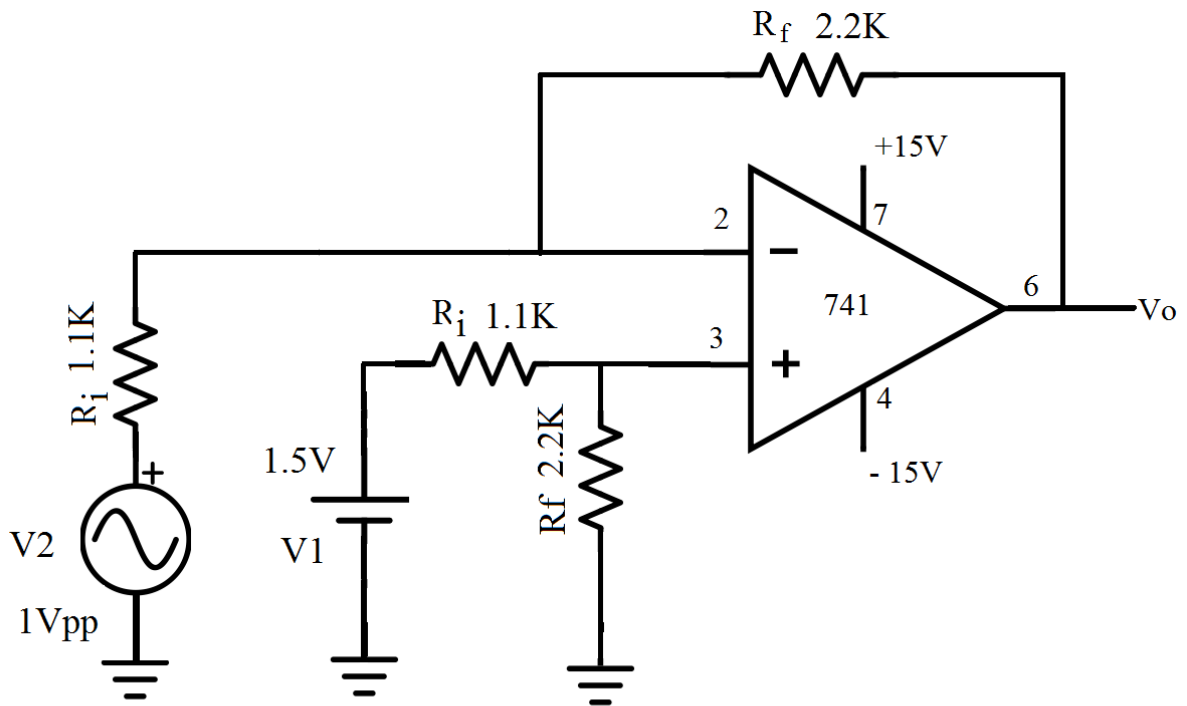

### Design:

Given the gain = 2

$$V_o = V_{o1} + V_{o2} = R_f/R_i(V_1 - V_2)$$

That is  $R_f / R_i = 2$

Let  $R_i = 1.1K\Omega$

Then  $R_f = 2.2K\Omega$

### Observations:

$V_1 = 1.5$  DC

$V_2 = 1V_{pp}$  sine wave

Then  $V_o = ?$

### Graph:



## Experiment No 3.1

### ZERO CROSSING DETECTOR

**Aim:** To design and setup a zero crossing detector circuit with OP AMP 741C and plot the waveforms.

**Objectives:** After completion of this experiment, student will be able to design and setup a zero crossing detector using OP AMP.

#### Equipments/Components:

Sl .No	Name and Specification	Quantity required
1	Dual power supply +/- 15V	1
2	Function generator (0- 1MHz)	1
3	Oscilloscope	1
4	Bread board	1
5	IC 741C	1
6	Probes and connecting wires	As required.

#### Principle:

It is the open loop/ saturation mode operation of op-amp. Here the signal is given the non-inverting terminal. So the output signal is in phase with the input signal. Such a circuit is called non-inverting zero crossing detector. In open loop configuration, the gain of the opamp is very high, so when the input voltage is above zero voltage, output of the circuit goes to +  $V_{sat}$  which is approximately +13V. Similarly when the input voltage is below zero voltage, the output goes to -  $V_{sat}$  which is approximately -13V

#### Procedure:

1. Check the components.
2. Setup the circuit on the breadboard and check the connections.
3. Switch on the power supply.
4. Give  $V_{in} = 2 V_{pp}/ 1KHz$  sine wave.
5. Observe input and output on the oscilloscope simultaneously.
6. Note down and draw the input and output waveforms on the graph.
7. Verify the output .

#### Result:

#### Inference:



**Circuit Diagram**

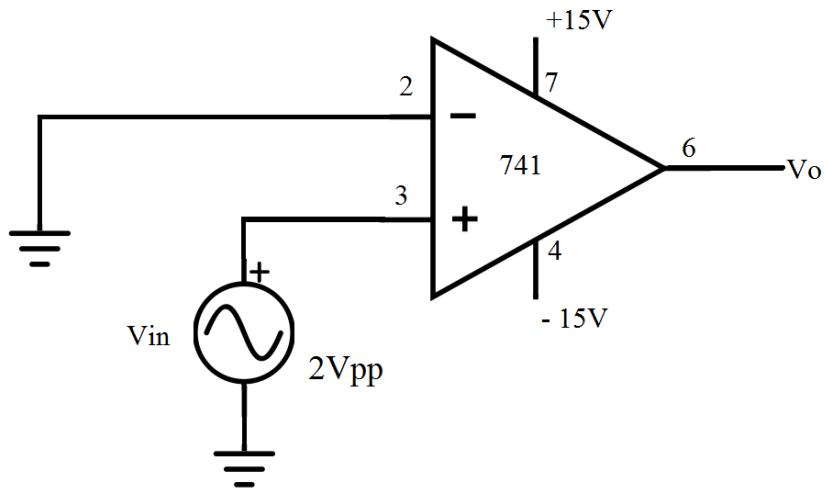

**Graph:**



## Experiment No 3.2

### SCHMITT TRIGGER

**Aim:** To design and setup a Schmitt trigger, plot the input output waveforms and measure  $V_{UT}$  and  $V_{LT}$ .

**Objectives:** After completion of this experiment, student will be able to design and setup a Schmitt trigger circuit using OP AMP.

#### Equipments/Components:

Sl .No	Name and Specification	Quantity required
1	Dual power supply +/- 15V	1
2	Function generator(0- 1MHz)	1
3	Oscilloscope	1
4	Bread board	1
5	IC 741C	1
6	Resistor	3
7	Probes and connecting wires	As required.

#### Principle:

It is a regenerative comparator or it is a comparator with hysteresis. This circuit uses positive feedback and the op-amp is operated in saturation. The output can take two values  $+V_{sat}$  and  $-V_{sat}$ . When output =  $+V_{sat}$ , the voltage appearing at the non-inverting terminal is  $V_{UT}$  or  $UTP = +V_{sat} (R_1/R_1+R_2)$  called the upper threshold point. Similarly When output =  $-V_{sat}$ , the voltage appearing at the non-inverting terminal is  $V_{LT}$  or  $LTP = -V_{sat} (R_1/R_1+R_2)$  called the lower threshold point. When  $V_{in}$  is greater than UTP, the output will switch from  $+V_{sat}$  to  $-V_{sat}$ . Similarly When  $V_{in}$  is less than LTP; the output will switch from  $-V_{sat}$  to  $+V_{sat}$  which is shown in the graph. The difference between UTP-LTP is called hysteresis. Hysteresis avoids false triggering of the circuit by noise. Hysteresis curve is the plot of  $V_o$  versus  $V_{in}$ . Schmitt trigger circuit is used to convert any irregular wave into square wave.

#### Procedure:

1. Check the components.
2. Setup the circuit on the breadboard and check the connections.
3. Switch on the power supply.
4. Give  $V_i = 10 V_{pp} / 1KHz$  sine wave.
5. Observe input and output on two channels of oscilloscope simultaneously.
6. Note down and draw the input and output waveforms on the graph.

#### Result:



<https://mail.gptcthirurangadi.in>

**Inference:**

*(Note: The experiment may be repeated for different values of UTP and LTP)*



### Circuit Diagram

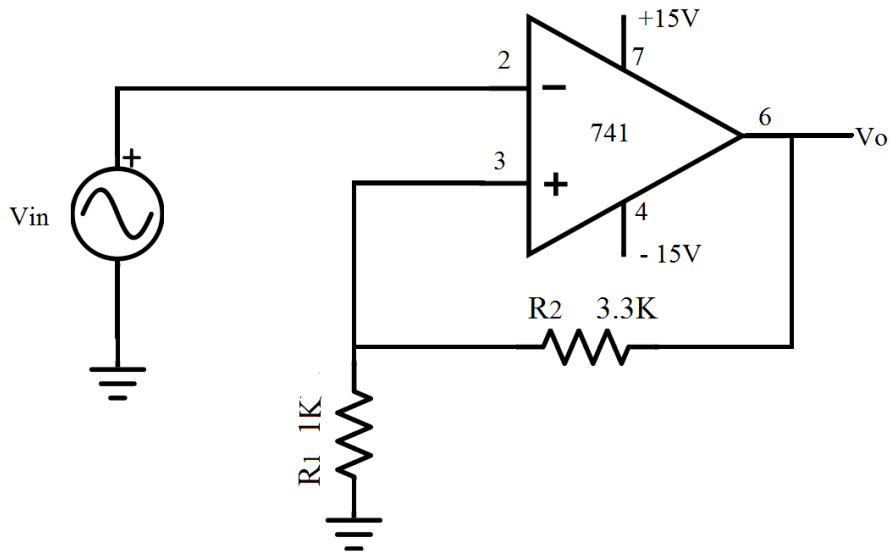

### Design:

$$UTP = +V_{sat} \left( \frac{R_1}{R_1 + R_2} \right)$$

Let  $UTP = +3V$  and  $LTP = -3V$ ,

$$V_{sat} = +13V$$

$$UTP, +3 = +13 \left( \frac{R_1}{R_1 + R_2} \right)$$

Let  $R_1 = 1 K\Omega$

Then  $R_2 = 3.3 K\Omega$

### Observations:

$UTP = ?$

$LTP = ?$

### Graph:





## Experiment No 4.1

### DIFFERENTIATOR

**Aim:** To design and setup a Differentiator circuit using OP AMP 741C and plot their pulse response.

**Objectives:** After completion of this experiment, student will be able to design and setup a differentiator circuit using OP AMP.

#### Equipments/Components:

Sl. No	Name and Specification	Quantity required
1	Dual power supply +/- 15V	1
2	Function generator (0- 1MHz)	1
3	Oscilloscope	1
4	Bread board	1
5	IC 741C	1
6	Resistor	1
7	Capacitor	1
8	Probes and connecting wires	As required.

#### Principle:

It is an opamp circuit which performs the mathematical operation of differentiation. That is the output waveform is the derivative or differential of the input voltage. That is  $V_o = -R_f C d(V_{in})/dt$ . The differentiator circuit is constructed from basic inverting amplifier by replacing the input resistance  $R_i$  with capacitor  $C$ . This circuit also works as high pass filter.

#### Procedure:

1. Check the components.
2. Setup the circuit on the breadboard and check the connections.
3. Switch on the power supply.
4. Keep the oscilloscope in AC coupling mode.
5. Give  $V_i = 2V_{pp}$ , 1KHz square wave.
6. Observe input and output on two channels of the oscilloscope simultaneously.
7. Note down and draw the input and output waveforms on the graph.

#### Result:

#### Inference:



**Circuit Diagram:**

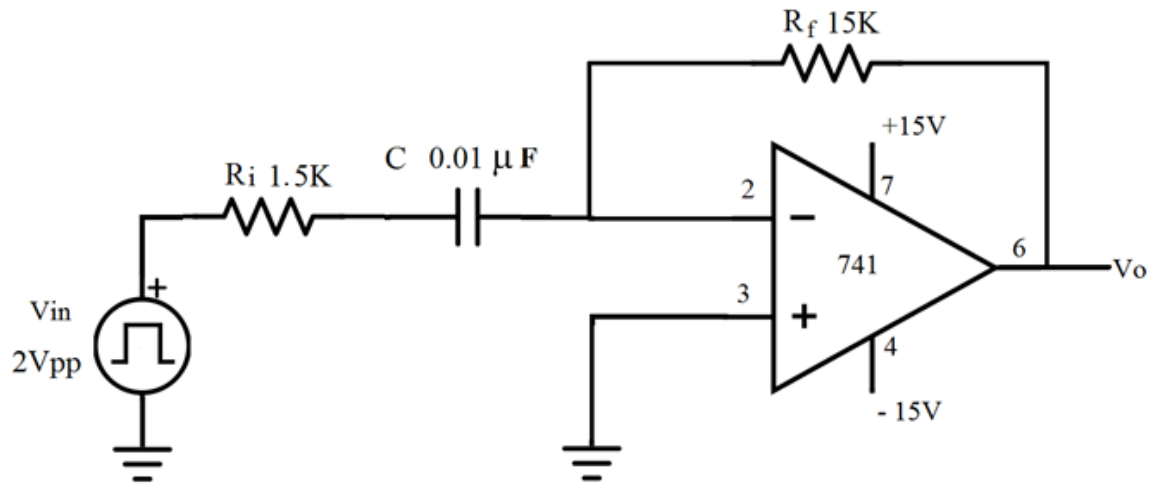

**Design:**

Given  $f = 1 \text{ KHz}$

So  $T = 1/f = 1 \text{ ms}$

Design equation is  $T = 2\pi R_f C$

Let  $C = 0.01 \mu\text{F}$

Then  $R_f = 15 \text{ K}\Omega$

Let  $R_i = R_f/10 = 1.5 \text{ K}\Omega$

**Graph:**



## Experiment No 4.2

### INTEGRATOR

**Aim:** To design and setup an integrator circuit using OP AMP 741C and plot its pulse response.

**Objectives:** After completion of this experiment, student will be able to design and setup an integrator circuit using OP AMP.

#### Equipments/Components:

Sl. No	Name and Specification	Quantity required
1	Dual power supply +/- 15V	1
2	Function generator (0-1MHz)	1
3	Oscilloscope	1
4	Bread board	1
5	IC 741C	1
6	Resistor	1
7	Capacitor 0.01 $\mu$ F	1
8	Probes and connecting wires	As required.

#### Principle:

It is a closed loop op-amp circuit which performs the mathematical operation of integration. That is the output waveform is the integral of the input voltage and is given by  $V_o = (-1/R_f C) \int V_{in} dt$ . The integrator circuit is constructed from basic inverting amplifier by replacing the feedback resistance  $R_f$  with capacitor  $C$ . This circuit also works as low pass filter.

#### Procedure:

1. Check the components.
2. Setup the circuit on the breadboard and check the connections.
3. Switch on the power supply.
4. Give  $V_i = 2V_{pp}$ , 1KHz square wave.
5. Keep the oscilloscope in AC coupling mode.
6. Observe input and output on two channels of the oscilloscope simultaneously.
7. Draw the input and output waveforms on the graph.

#### Result:

#### Inference:



**Circuit Diagram:**

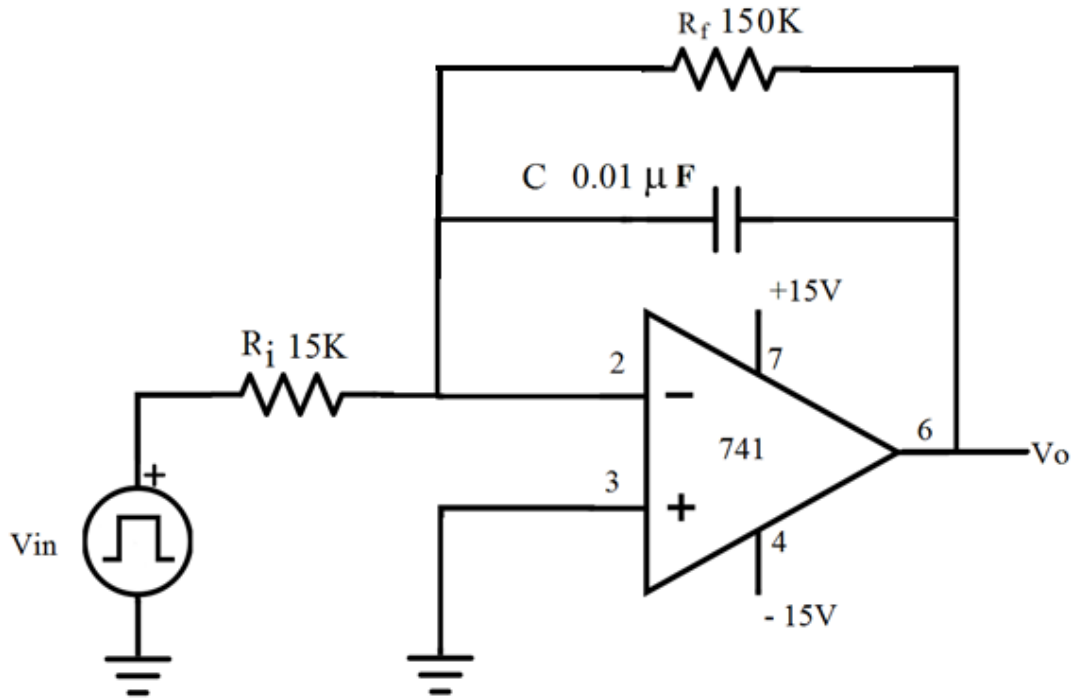

**Design:**

Given  $f = 1 \text{ KHz}$

So  $T = 1/f = 1 \text{ ms}$

Design equation is  $T = 2\pi R_i C$

Let  $C = 0.01 \mu\text{F}$

Then  $R_i = 15 \text{ K}\Omega$

Take  $R_f = 10R_i = 150 \text{ K}\Omega$

**Graph:**



## Experiment No 5

### SYMMETRICAL AND ASYMMETRICAL ASTABLE MULTIVIBRATORS USING OP AMP

**Aim:** To design and setup symmetrical and asymmetrical astable multivibrators using Op-amp 741, plot the waveforms and measure the frequency of oscillation

**Objectives:** After completion of this experiment, student will be able to design and setup an astable multivibrators circuit using OP AMP.

#### Equipments/Components:

Sl. No	Name and Specification	Quantity required
1	Dual power supply +/- 15V	1
2	Function generator (0- 1MHz)	1
3	Oscilloscope	1
4	Bread board	1
5	IC 741C	1
6	Resistor	5
7	Capacitor 0.1 $\mu$ F	1
8	Diode 1N4001	2
9	Probes and connecting wires	As required.

#### Principle:

In this circuit, the opamp is operated in saturation mode and the output swings between  $+V_{sat}$  and  $-V_{sat}$  giving square wave output. This circuit is also called free running oscillator or square wave generator. A positive feedback with feedback factor  $\beta = R_1 / (R_1 + R_2)$  is provided to the non-inverting terminal. When  $V_o = +V_{sat}$ , the capacitor C starts to charge to  $+V_{sat}$  through R. when the capacitor voltage crosses  $+\beta V_{sat}$ , output switches from  $+V_{sat}$  to  $-V_{sat}$ . Now the voltage appearing at the non-inverting terminal is  $-\beta V_{sat}$  and capacitor discharges through R towards  $-V_{sat}$ . When the capacitor voltage crosses  $-\beta V_{sat}$ , the output switches from  $-V_{sat}$  to  $+V_{sat}$  and this process continues to generate square wave output with time period  $T = T_{on} + T_{off} = 2RC \ln[(1+\beta)/(1-\beta)]$ . In asymmetrical astable multivibrators, the charging and discharging time of capacitor is made unequal to get asymmetrical square wave with different  $T_{on}$  and  $T_{off}$ .



**Procedure:**

1. Check the components.
2. Setup the symmetric astable multivibrator circuit on the breadboard and check the connections.
3. Switch on the power supply.
4. Observe output and capacitor voltage on two channels of the oscilloscope simultaneously.
5. Draw the waveforms on the graph.
6. Measure the frequency of oscillation and duty cycle .
7. Repeat the procedures for asymmetric astable multivibrator.

**Result:**

**Inference:**

*(Note: The experiment may be repeated for different values of frequency and duty cycle)*



### a) SYMMETRICAL ASTABLE MULTIVIBRATOR

Circuit Diagram:

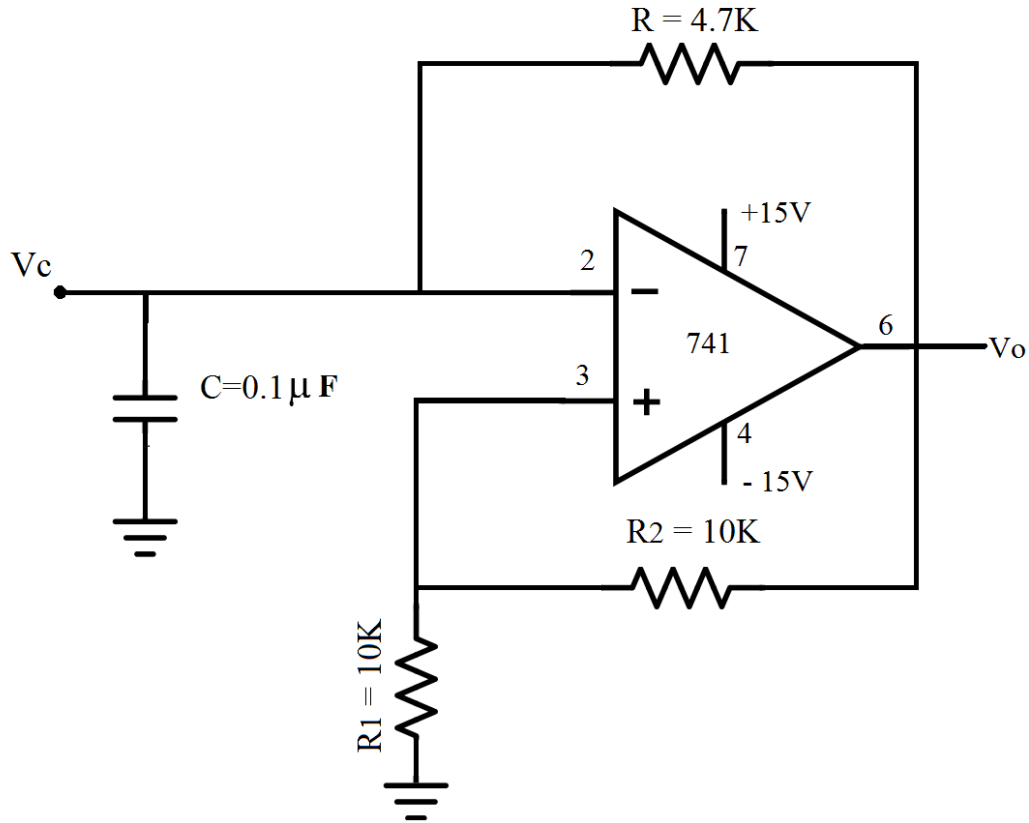

### SYMMETRICAL ASTABLE MULTIVIBRATOR

*Note: Use 10KΩ pot instead of R = 4.7KΩ resistor and vary it for accurate time period.*

**Design:**

Given  $f = 1 \text{ KHz}$

So  $T = 1/f = 1\text{ms}$

And  $\beta = R_1 / (R_1 + R_2)$

Let  $R_1 = 10\text{K}\Omega$ , and  $R_2 = 10\text{K}\Omega$

Then  $\beta = 0.5$

Therefore  $T = 2.2RC = 1\text{ms}$



Let  $C = 0.1\mu\text{F}$

Then  $R = 4.7\text{K}\Omega$

### b) ASYMMETRICAL ASTABLE MULTIVIBRATOR

**Circuit Diagram:**

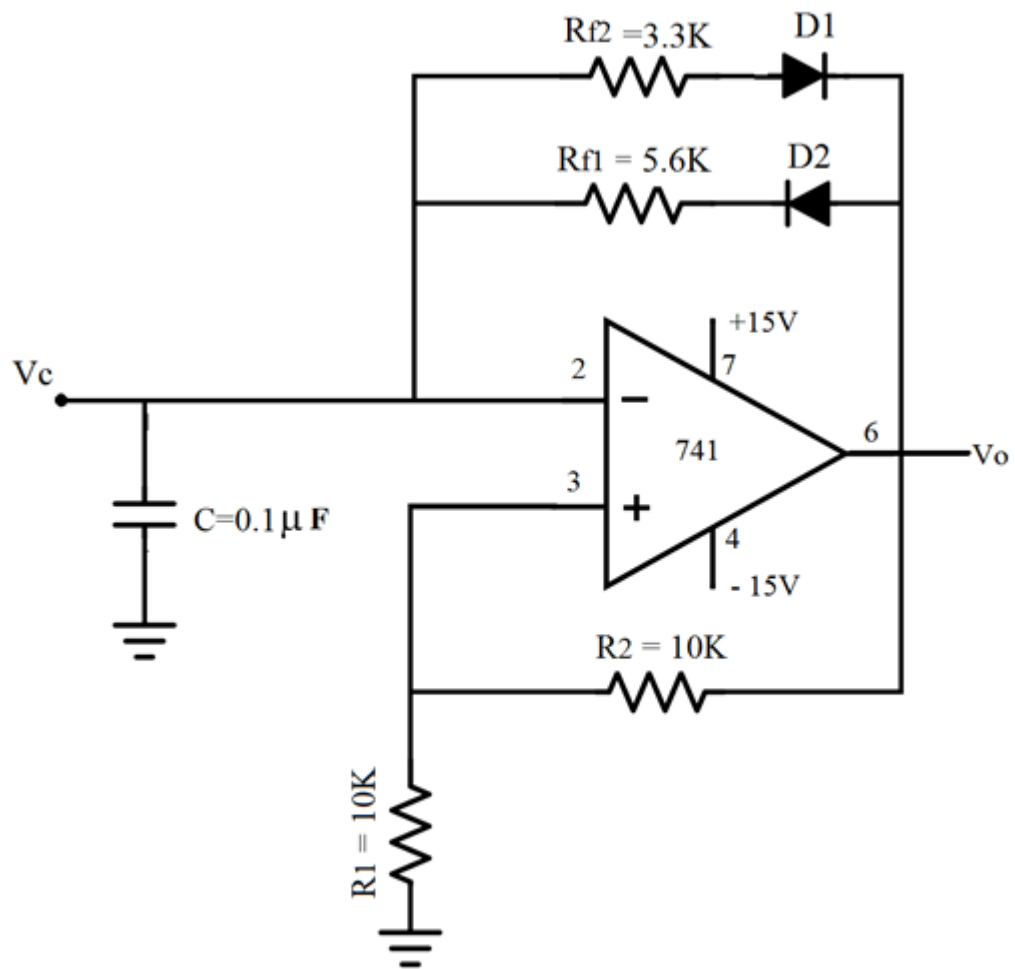

### ASYMMETRICAL ASTABLE MULTIVIBRATOR

**Note:** Use two  $10\text{K}\Omega$  potentiometers instead of  $R_{f1}$  and  $R_{f2}$  resistor and vary it for accurate time period.

**Design:**

Given  $f = 1\text{ KHz}$

So  $T = T_{\text{on}} + T_{\text{off}} = 1/f = 1\text{ms}$





Also Duty cycle =  $T_{on}/(T_{on}+T_{off}) = 0.66$  or 66%

Solving above two equations,  $T_{on} = 0.66\text{ms}$

$$T_{off} = 0.33\text{ms}$$

For  $\beta=0.5$ ,

$$T_{on} = 1.1R_{f1}C = 0.66\text{ms}$$

$$\text{Let } C = 0.1\mu\text{F}$$

$$\text{Then } R_{f1} = 6.2\text{K}\Omega = 5.6\text{K}\Omega \text{ (Std)}$$

$$\text{Similarly } T_{off} = 1.1R_{f2}C = 0.33\text{ms}$$

$$\text{Then } R_{f2} = 3\text{K}\Omega = 3.3\text{K}\Omega \text{ (Std)}$$

### Observation:

#### a) Symmetrical astable multivibrators

$$V_o(\text{p-p}) = ?$$

$$f = ?$$

$$\text{Duty cycle} = ?$$

#### b) Asymmetrical astable multivibrators

$$V_o(\text{p-p}) = ?$$

$$f = ?$$

$$\text{Duty cycle} = ?$$

### Graph:

#### a) Symmetrical astable multivibrators

#### b) Asymmetrical astable multivibrators



## Experiment No. 6

### MONOSTABLE MULTIVIBRATOR USING OP AMP

**Aim:** To design and setup a monostable multivibrator using Op-amp 741 and

- (i) Plot the waveforms (ii) Measure the time delay

**Objectives:** After completion of this experiment the students are able to design and set up the monostable multivibrator circuit and delay circuits.

#### Equipments/Components

Sl. No.	Name and specification	Quantity
1	Dual Power Supply +/-15V	1
2	Resistors	4
3	Capacitor 0.1 $\mu$ F;0.01 $\mu$ F	1 each
4	IC $\mu$ A 741	1
5	Function generator (0-1)MHz	1
6.	Oscilloscope	1
7.	Diode 1N 4001	2
8	Bread board	1
9	Connecting wires and probes	As required

#### Principle:

The monostable multivibrator is also called as one shot multivibrator. The circuit produces a single pulse of specified duration in response to each external trigger pulse. It always has one stable state (+V<sub>sat</sub>). When an external trigger is applied, the output state changes and the new state is called quasi stable state (-V<sub>sat</sub>). The circuit remains in this state for a fixed interval of time and then it returns to the original state after this interval. This time interval is determined discharging of the capacitor from 0.7V to - $\beta$ V<sub>sat</sub>. The time period of quasi stable state or the delay is given by

$$T = 0.69RC$$

#### Procedure:

1. Check the components.
2. Setup the monostable multivibrator circuit on the breadboard and check the connections.
3. Switch on the power supply.
4. Put the function generator output to square wave mode. Adjust the amplitude to 5V.



5. Observe trigger input , output and capacitor voltage on different channels of the oscilloscope simultaneously.
6. Draw the waveforms on the graph.
7. Measure the time delay .

**Result:**

**Inference:**

*(Note: The experiment may be repeated for different values of time delay)*



**Circuit Diagram:**

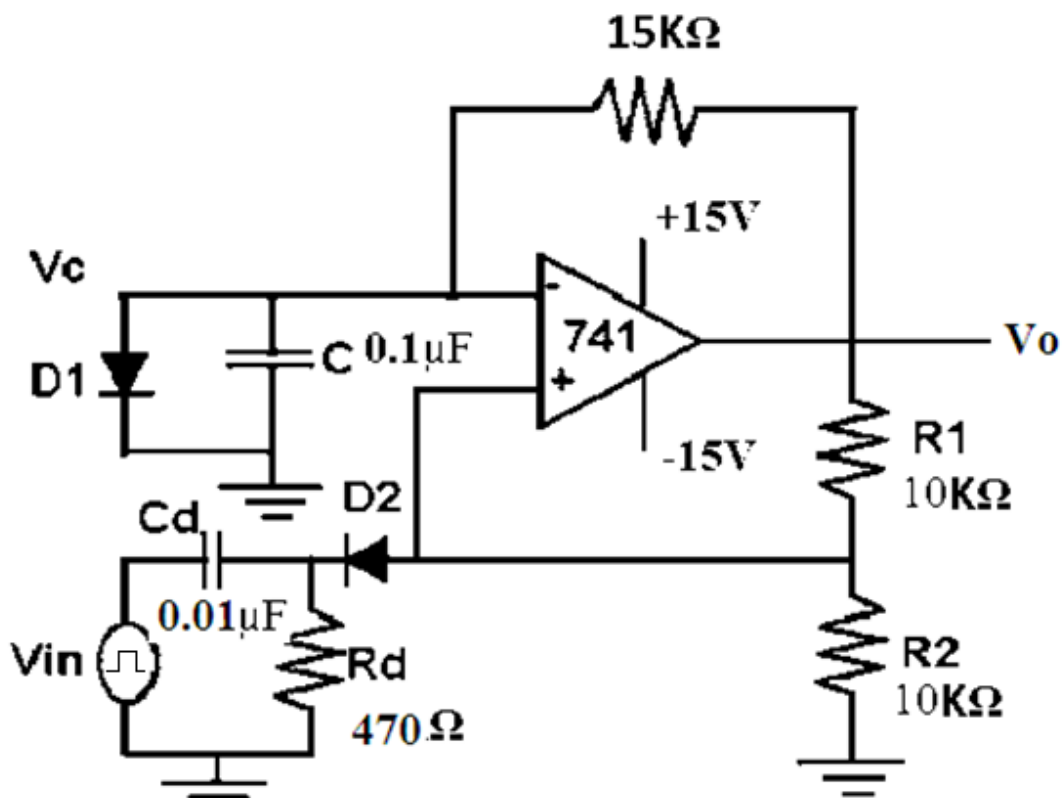

**Design:**

Time Period  $T = 0.69RC$

Let  $T = 1\text{ms}$ ; and  $C = 0.1\mu\text{F}$ .

Then  $R = 15\text{K}\Omega$

Feedback factor  $\beta = R_2/(R_1+R_2)$

Let  $\beta = 0.5$  or  $1/2$

$R_2/(R_1+R_2) = 1/2$

If  $R_1=10\text{K}\Omega$ ;  $R_2=10\text{K}\Omega$

**For triggering circuit**

$R_d C_d = 0.0016t$

Let  $t = 3\text{ms}$  and  $C_d = 0.01\mu\text{F}$ ; then  $R_d = 470\Omega$

$D_1$  &  $D_2$  are diodes 1N 4001

**Observations:**

Measured time period or delay =?

**Graph:**



## Experiment No. 7

### RC PHASE SHIFT OSCILLATOR USING OP AMP

**Aim:** To Design and setup a RC phase shift oscillator using Op-Amp 741 and (i) Plot the output waveform (ii) Measure the frequency of oscillation

**Objectives:** After completion of this experiment the students are able to design and set up the RC phase shift oscillator for desired frequency.

#### Equipments/Components

Sl. No.	Name and specification	Quantity
1	Dual Power Supply +/-15V	1
2	Resistors	5
3	Capacitor 0.01 $\mu$ F	3
4	IC $\mu$ A 741	1
5	Oscilloscope	1
6	Bread board	1
7	Connecting wires and probes	As required

#### Principle:

RC phase shift oscillator uses op-amp, in inverting amplifier mode and the circuit generates its own output signal. It consists of an op-amp as an amplifier and 3 RC cascaded network as the feedback circuit. Since the op-amp is used in the inverting mode, any signal that appears at the inverting terminal is shifted by  $180^{\circ}$  at the output. An additional  $180^{\circ}$  phase shift required for oscillation is provided by the cascaded RC network. Thus the total phase shift around the circuit is  $360^{\circ}$  or  $0^{\circ}$ . At some specific frequency, the phase shift of the cascaded RC network is exactly  $180^{\circ}$  and feedback factor is  $1/29$ . If the gain of the amplifier is 29, the total loop gain of the circuit becomes 1. The circuit will oscillate at this specific frequency and is given by

$$f_{\text{oscillation}} = \frac{1}{2\pi RC\sqrt{6}}$$

#### Procedure:

1. Check the components.
2. Setup the RC phase shift oscillator circuit on the breadboard and check the connections.
3. Switch on the power supply.



<https://mail.gptcthirurangadi.in>

4. Observe output voltage on oscilloscope.
5. Draw the waveforms on the graph.
6. Measure the frequency of oscillation .

**Result:**

**Inference:**



**Circuit Diagram:**

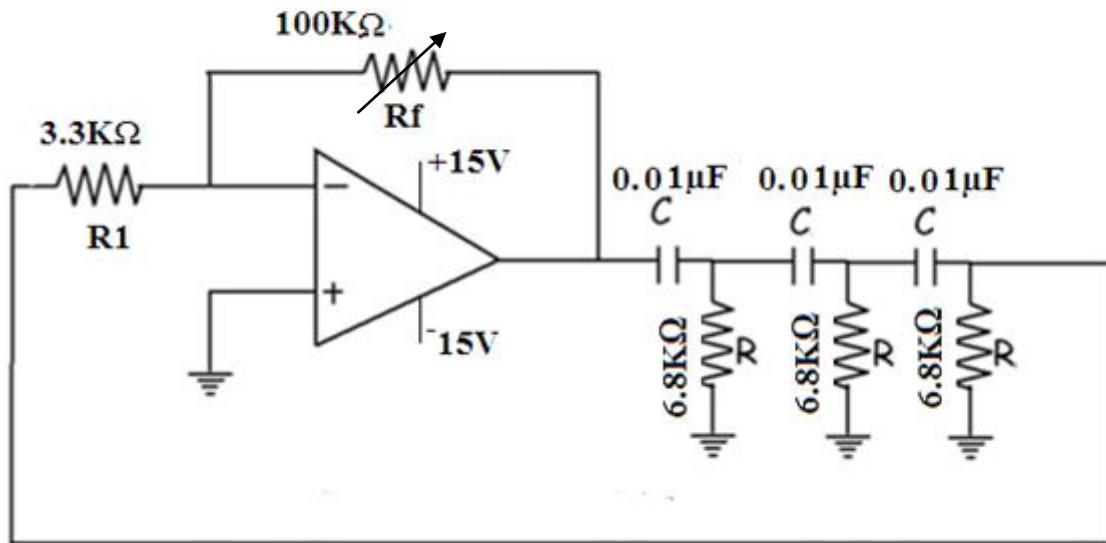

Note: Instead of 100KΩ pot, use 47KΩ pot in series with 68KΩ resistor for distortion less sine wave

**Design:**

$$f_{\text{oscillation}} = \frac{1}{2\pi RC\sqrt{6}}$$

Let  $f = 1 \text{ KHz}$ , and  $C = 0.01\mu\text{F}$

$R = 6.8\text{K}\Omega$

Gain = 29

$R_f/R_1 = 29$

If  $R_1 = 3.3\text{K}\Omega$  ;  $R_f = 95.7\text{K}\Omega$  Use 100KΩ pot

**Observations:**

Measured frequency of oscillation is =?

**Graph:**



## Experiment No. 8

### WIEN BRIDGE OSCILLATOR USING OP AMP

**Aim:** To design and construct a Wien bridge oscillator using Op-Amp 741 and

- (i) Plot the output waveform (ii) Measure the frequency of oscillation

**Objectives:** After completion of this experiment the students are able to design and set up the Wien oscillator for desired frequency

#### Equipments/Components

Sl. No.	Name and specification	Quantity
1	Dual Power Supply +/-15V	1
2	Resistors	4
3	Capacitor 0.1 $\mu$ F	2
4	IC $\mu$ A 741	1
5	Oscilloscope	1
6	Bread board	1
7	Connecting wires and probes	As required

#### Principle:

It is the commonly used audio frequency oscillator which employs both positive and negative feedback. The feedback signal is connected in the non-inverting input terminal so that the amplifier is working in non-inverting mode. The Wien bridge circuit is connected between amplifier input terminal and output terminal. The bridge has a series RC network in one arm and a parallel RC network in the adjoining arm. In the remaining two arms of the bridge, resistor R1 and Rf are connected. The phase angle criterion for oscillation is that the total phase shift around the circuit must be zero. This condition occurs when bridge is balanced. At resonance, the frequency of oscillation is exactly the resonance frequency of balanced Wien bridge and is given by  $f_0 = 1 / (2\pi RC)$ . At this frequency, the gain required for sustained oscillation is 3. It is provided by the non-inverting amplifier with  $\text{Gain} = 1 + (R_f/R_1) = 3$

#### Procedure:

1. Check the components.
2. Setup the Wien bridge oscillator circuit on the breadboard and check the connections.
3. Switch on the power supply.
4. Observe output voltage on oscilloscope.
5. Draw the waveforms on the graph.
6. Measure the frequency of oscillation .





<https://mail.gptcthirurangadi.in>

**Result:**

**Inference:**



**Circuit Diagram:**

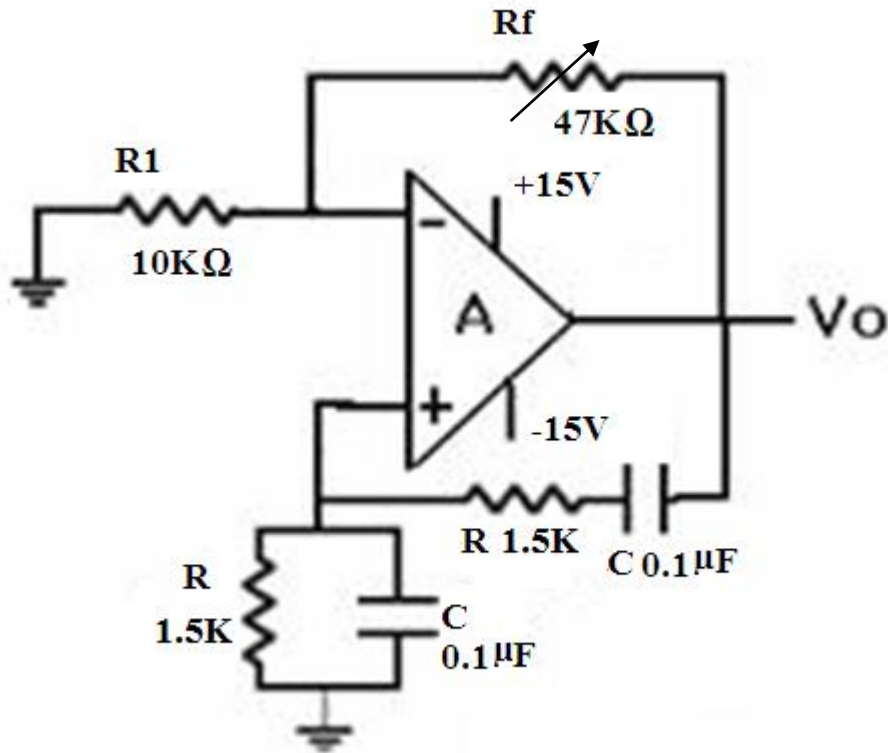

*Note:* Instead of 47KΩ pot, use 10KΩ pot in series with 22KΩ resistor for distortion less sine wave

**Design:**

$$f = \frac{1}{2\pi RC}$$

Let  $f = 1\text{KHz}$ , and  $C = 0.1\mu\text{F}$

$R = 1.5\text{K}\Omega$

Gain=3

$$1 + (R_f/R_1) = 3$$

If  $R_1 = 10\text{K}\Omega$ ,  $R_f = 20\text{K}\Omega$  Use 47KΩ pot

**Observations:**

Measured frequency of oscillation is =?

**Graph:**



## Experiment No. 9

### ASTABLE MULTIVIBRATOR USING IC 555

**Aim:** To design and setup symmetrical and asymmetrical astable multivibrators using IC 555 and (i) Plot the output waveform (ii) Measure the frequency of oscillation

**Objectives:** After completion of this experiment the students are able to design and set up the astable multivibrator using timer IC 555.

#### Equipments/Components

Sl. No.	Name and specification	Quantity
1	Power Supply 10V	1
2	Resistors	4
3	Capacitor 0.01 $\mu$ F	2
4	IC 555	1
5	Diode 1N 4001	1
6	Oscilloscope	1
7	Bread board	1
8	Connecting wires and probes	As required

**Principle:** The 555 timer is a highly stable device for generating accurate time delay .The internal structure of 555 is shown in which there are two comparators, a flip flop, an output stage, a voltage divider network and a transistor. The comparator is a device whose output is high when the non-inverting input voltage is greater than inverting input voltage and output is low when inverting input voltage is greater than non-inverting input voltage. The voltage divider network consist of three 5K $\Omega$  resistors and provides a trigger voltage level of  $1/3V_{CC}$  and threshold voltage level of  $2/3V_{CC}$ .The control voltage is used for changing the threshold and trigger voltages externally.

**555 as Astable multivibrator:** Astable multivibrator means it has no stable states. It has two quasi stable states (high and low).In the figure given , there are 2 external resistors  $R_A$  and  $R_B$  and a capacitor C. When the power is given to the circuit the capacitor C will charge towards  $V_{CC}$  through  $R_A$  and  $R_B$  ,when the capacitor voltage exceeds the level of  $2/3V_{CC}$  (threshold voltage) the output of the comparator I goes high which resets the flip flop so the output Q of the flip-flop becomes low and  $\bar{Q}$  becomes high. Now the transistor which is connected to  $\bar{Q}$  becomes ON. The capacitor C started to discharge through  $R_B$  and transistor exponentially. When voltage across capacitor reaches just below of  $1/3V_{CC}$  (trigger voltage) the output of the comparator II becomes high and sets the flip flop, turning OFF the transistor since it is connected to the  $\bar{Q}$  of the flip flop. The capacitor C will begin to charge towards  $V_{CC}$  through  $R_A$  and  $R_B$ . when the capacitor voltage exceeds the level of  $2/3V_{CC}$ , the output of the comparator I goes high which resets the flip-flop so the output Q of the flip flop becomes low



and  $\bar{Q}$  becomes high. The cycle continues which gives a square wave at the output (pin 3) and charging and discharging wave form across capacitor (pin 2&6).

**555 as Symmetrical astable multivibrator:** Symmetrical astable multivibrator means the multivibrator has equal ON time & OFF time (duty cycle =50%).we can achieve this by making the charging (towards  $2/3 V_{CC}$ ) and discharging (towards  $1/3V_{CC}$ ) process of capacitor through equal resistance path. In the circuit diagram the diode (1N 4001) is connected across the resistor  $R_B$  so the charging of capacitor above threshold voltage ( $2/3V_{CC}$ ) takes place through the resistor  $R_A$  and forward biased diode. The discharging below trigger voltage ( $1/3V_{CC}$ ) is through the resistor  $R_B$ . Since  $R_A$  and  $R_B$  have same value, charging and discharging time of the capacitor will be same.

**555 as Asymmetrical astable multivibrator:** Asymmetrical astable multivibrator means the multivibrator has unequal ON time & OFF time (duty cycle other than50%).In the circuit diagram the charging of capacitor towards threshold voltage ( $2/3V_{CC}$ ) takes place through the resistor  $R_A$  and  $R_B$ , discharging towards trigger voltage ( $1/3V_{CC}$ ) is through the resistor  $R_B$ . Since charging and discharging process of the capacitor takes place through different resistance path, the charging time and discharging time of the capacitor will be different, which results in asymmetrical output wave.

### Procedure:

1. Check the components.
2. Setup the symmetric astable multivibrator circuit on the breadboard and check the connections.
3. Switch on the power supply.
4. Observe output and capacitor voltage on different channels of the oscilloscope simultaneously.
5. Draw the waveforms on the graph.
6. Measure the frequency of oscillation and duty cycle .
7. Repeat the procedures for asymmetric astable multivibrator.

### Result:

### Inference



a) Symmetrical astable multivibrator:

Circuit Diagram :

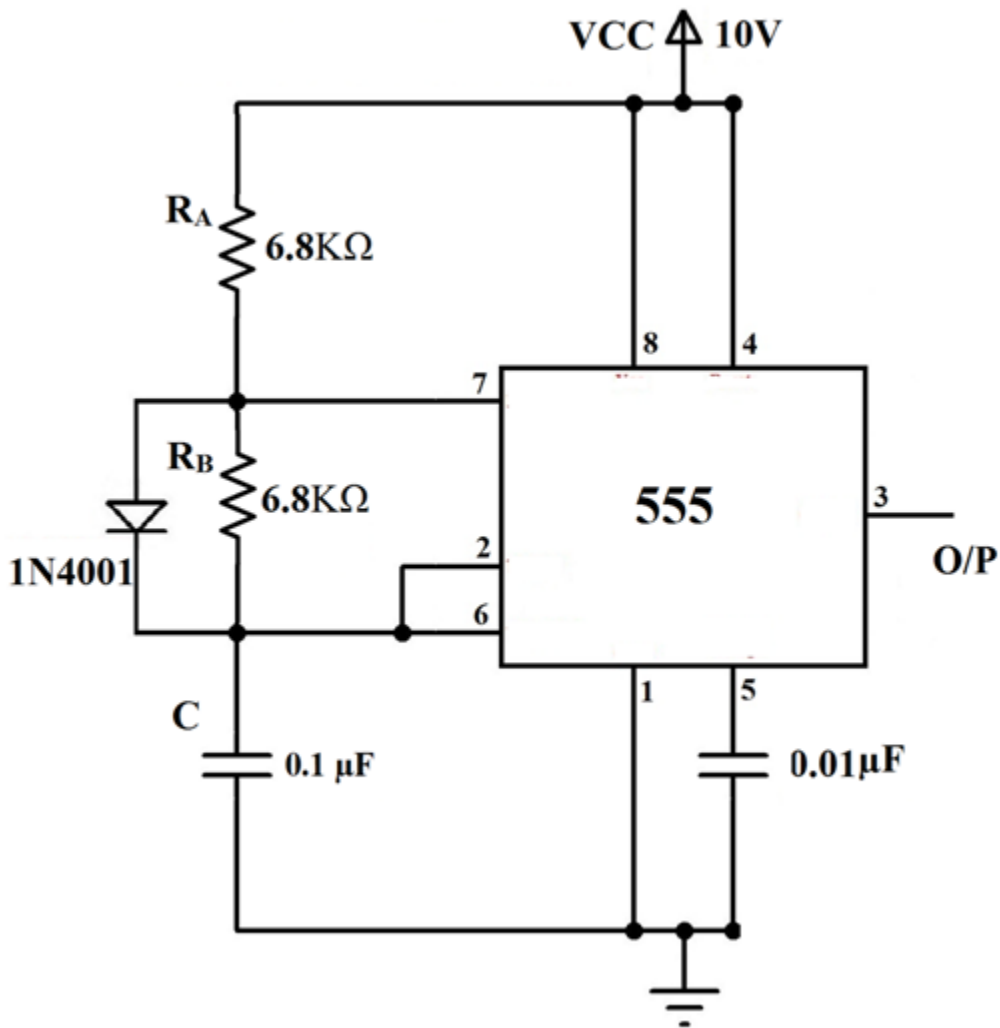

**Internal diagram of IC 555**

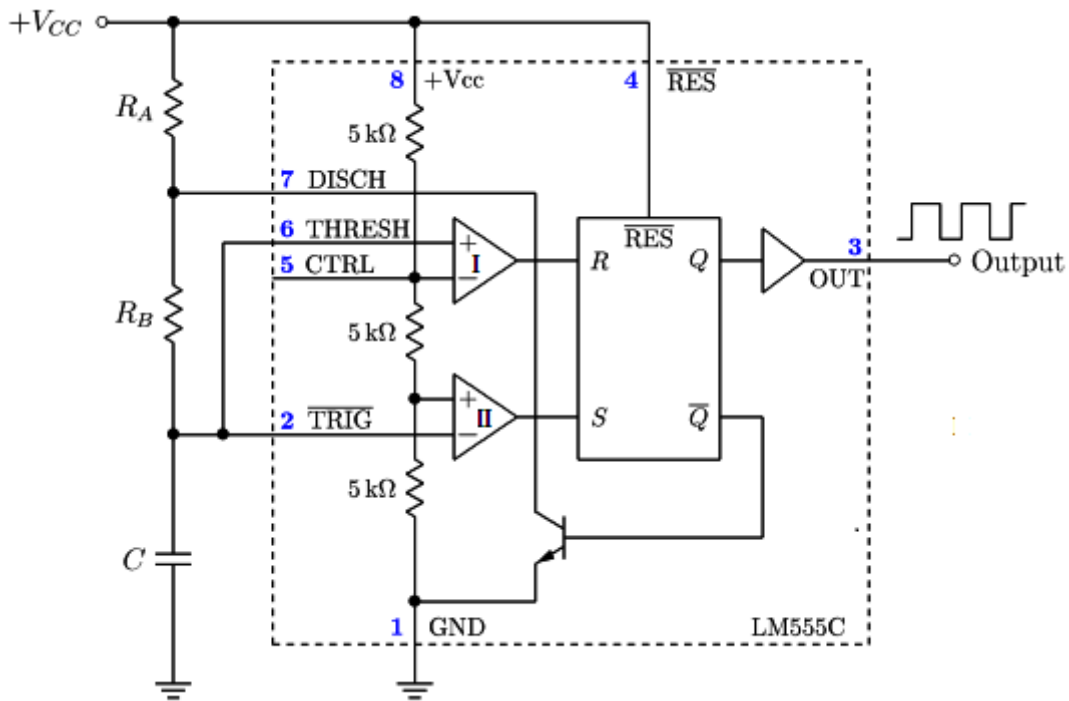

**IC 555 Pin out**

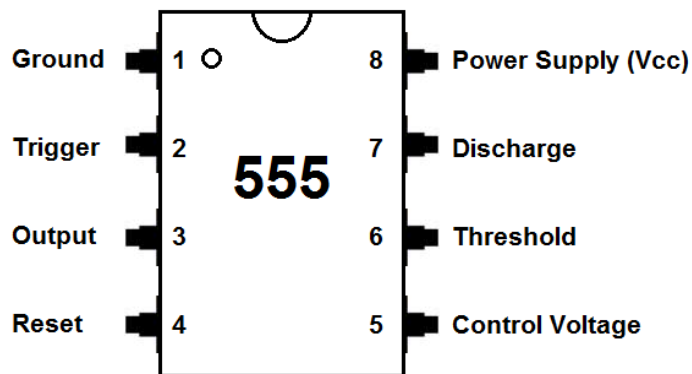

**Design:**

**SYMMETRICAL ASTABLE MULTIVIBRATOR:**

$$T = 0.69(R_A + R_B)C \quad \text{or} \quad f = 1.44 / (R_A + R_B)C$$



Duty cycle  $D = 0.5$  or 50%

$$D = R_A / (R_A + R_B) = 0.5$$

So  $R_A = R_B$

Let  $T = 1\text{ms}$ ; and  $C = 0.1\ \mu\text{F}$

$$0.693(R_A + R_B) 0.1\ \mu\text{F} = 1\text{ms}$$

$$R_A + R_B = 14.49\text{K}\Omega$$

or  $2 R_A = 14.49\text{K}\Omega$

$$R_A = 7.25\text{K}\Omega = 6.8\text{K}\Omega(\text{std})$$

$$R_B = 7.25\text{K}\Omega = 6.8\text{K}\Omega(\text{std})$$

**Observations:**

$T = ?$

Measured frequency of oscillation is =?

**Graph:**



b) Asymmetrical astable multivibrator:

Circuit Diagram :

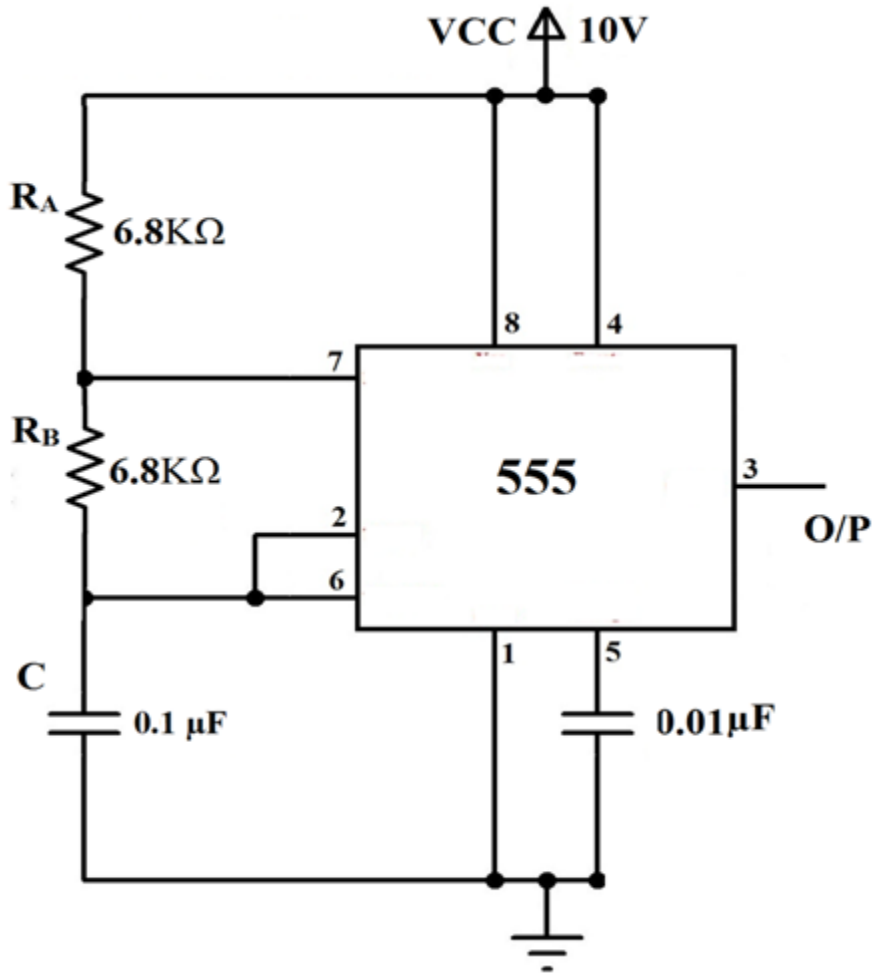

Design:

**ASYMMETRICAL ASTABLE MULTIVIBRATOR:**

$$T = 0.69 (R_A + 2R_B) C \quad \text{or} \quad f = 1.44 / \{ (R_A + 2R_B) C \}$$

Here  $T = t_1 + t_2$

$$t_1 = 0.69(R_A + R_B)C \quad (\text{charging})$$

$$t_2 = 0.69(R_B)C \quad (\text{discharging})$$

Let  $t_1 = 1\text{ms}$  ;  $t_2 = 0.5\text{ms}$  ;  $C = 0.1 \mu\text{F}$

$$0.69 R_B C = 0.5\text{ms}$$

$$R_B = 7.2 \text{ K}\Omega = 6.8\text{K}\Omega \text{ (std)}$$

$$0.69 (R_A + R_B) C = 1\text{ms}$$





$$R_A + R_B = 14.49 \text{ K}\Omega$$

$$R_A = 14.49 - R_B$$

$$R_A = 7.2 \text{ K}\Omega = 6.8 \text{ K}\Omega \text{ (std)}$$

**Observations:**

$$t_1 = ?$$

$$t_2 = ?$$

$$T = ?$$

Measured frequency of oscillation,  $f = ?$

Duty cycle = ?

**Graph:**



## Experiment No. 10

### MONOSTABLE MULTIVIBRATOR USING IC 555

**Aim:** To design and construct a monostable multivibrator using 555 IC and (i) Plot the output waveform (ii) Measure the time delay

**Objectives:** Upon completion of this experiment the students are able to design and setup monostable multivibrator using IC 555.

#### Equipments/Components

Sl. No.	Name and specification	Quantity
1	Power Supply 10V	1
2	Resistors	2
3	Capacitor 0.01 $\mu$ F, 0.1 $\mu$ F	2 +1
4	IC 555	1
5	Diode 1N 4001	1
6	Oscilloscope	1
7	Function generator 0 – 1MHz	1
8	Bread board	1
9	Connecting wires and probes	As required

#### Principle:

The monostable multivibrator has one stable state and one quasi stable state. Monostable multivibrator produces an output pulse with defined time period for each external trigger pulse applied. It comes out of the stable state only by use of an external signal called trigger.

When the output is low, that is, the circuit is in stable state. Upon application of trigger pulse to pin 2, the output of the comparator II becomes high which sets the flip flop high. As the output is high, the transistor becomes OFF since it is connected to the  $\bar{Q}$  of the flip flop. Capacitor starts to charge through R towards  $V_{CC}$ , as soon as the capacitor voltage crosses  $2/3 V_{CC}$  (threshold voltage) the output of the comparator I becomes high so the flip-flop will reset and out goes to low. At the same time transistor turns ON and hence capacitor rapidly discharges through the transistor. The output of this circuit remains low until a trigger pulse is again applied. The time during which the output remains high is given by  $T = 1.1 RC$ .

#### Procedure

1. Check the components.
2. Setup the monostable multivibrator circuit on the breadboard and check the connections.
3. Switch on the power supply.



<https://mail.gptcthirurangadi.in>

4. Put the function generator output to square wave mode. Adjust the amplitude to 5V.
5. Observe trigger input , output and capacitor voltage on different channels of the oscilloscope simultaneously.
6. Draw the waveforms on the graph.
7. Measure the time delay .

**Result:**

**Inference:**



**Circuit Diagram :**

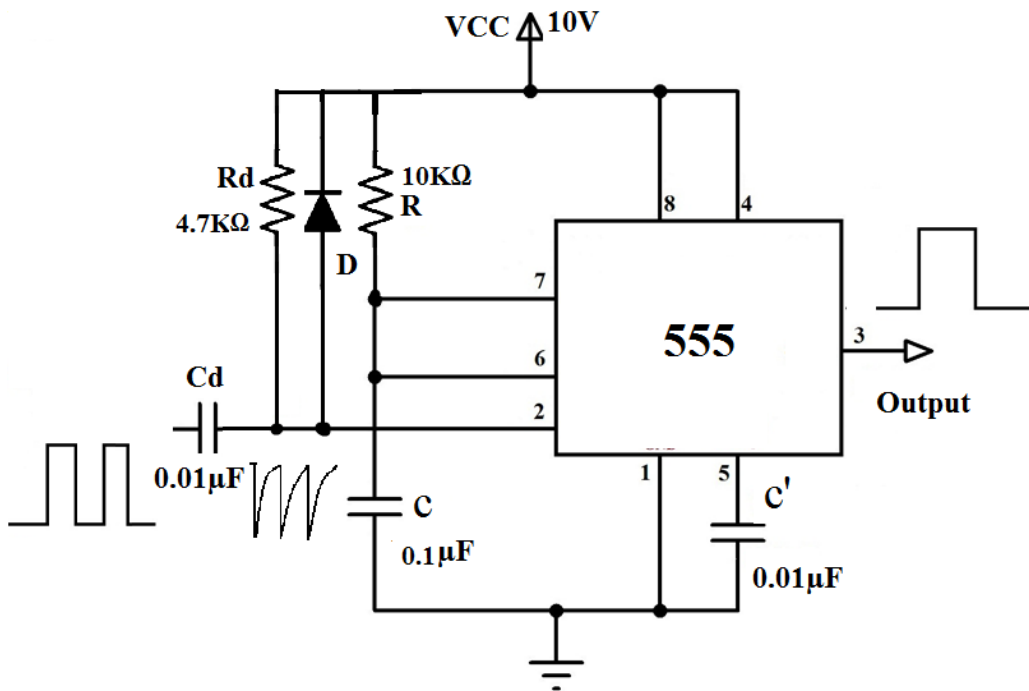

D is diode 1N4001

**Design:**

$$\text{Time period } T = 1.1RC$$

$$\text{Let } T = 1\text{ms} ; \quad C = 0.1\mu\text{F}$$

$$R = 1 \times 10^{-3} / (1.1 \times 0.1 \times 10^{-6})$$

$$R = 9.09 \times 10^3 \Omega = 10\text{K}\Omega \text{ (std)}$$

For triggering circuit

$$R_d C_d = 0.016t$$

$$\text{Let } t = 3\text{ms, and } C_d = 0.01 \mu\text{F} ; \quad \text{then } R_d = 4.7\text{K}\Omega$$

**Observations:**

Measured time period or delay=?

**Graph:**



## Experiment No. 11

### VOLTAGE CONTROLLED OSCILLATOR USING IC566

**Aim:** To set up voltage controlled oscillator using IC566 and plot the waveforms.

**Objectives:** After completion of this experiment, students will be able to construct a VCO using IC566 and will study how to vary frequency. He/ she will know the details of IC566

#### Equipments/Components

Sl. No.	Name and specifications	Quantity
1	Oscilloscope	1
2	Multimeter	1
3	Variable Power Supply (0-30V)	1
4	IC 566	1
5	Capacitors	2
6	Resistors	3
7	Potentiometer	1
8	Bread board	1
9	Connecting wires	As required

#### Principle:

VCO is an oscillator whose oscillating frequency varies in response to a control voltage  $V_c$ . NE/SE566 is a commonly available VCO. The frequency of oscillation is determined by an externally connected resistor  $R_1$  and capacitor  $C_1$ . The control voltage is applied at the control terminal (Pin5). The triangular voltage is obtained at Pin4 which is generated by alternately charging the capacitor  $C_1$  by one current source and discharging it linearly through another current source. The amount of charge and discharge voltage swing is determined by the Schmitt trigger. The Schmitt trigger also provides the square wave output at pin3.

#### Operation of VCO

The output voltage swing of the Schmitt trigger is set in the levels  $V_{cc}$  and  $0.5V_{cc}$ . Timing capacitor  $C_1$  is charged linearly or discharged by a constant current source. The current value can be controlled in two ways either by changing the control voltage  $V_c$  given at the modulating input (pin5) or by changing the timing resistor  $R_1$  connected externally. The voltage available at pin6 is same that of pin5. During charging of  $C_1$ , when the voltage across  $C_1$  exceeds  $0.5V_{cc}$ , the Schmitt trigger switches to LOW ( $0.5V_{cc}$ ) and the capacitor starts discharging when the voltage across  $C_1$  reduce to  $0.25V_{cc}$ , the Schmitt trigger switches to HIGH ( $V_{cc}$ ).



**Procedure:**

1. Check all the components
2. Set up circuit on the breadboard and check the connections
3. Switch on the power supply
4. Observe the waveform on the oscilloscope and measure the frequency
5. Vary the potentiometer R3 to see that output frequency changes.
6. Note down and draw the output waveform on the graph

**Result:**

**Inference:**



**Circuit diagram:**

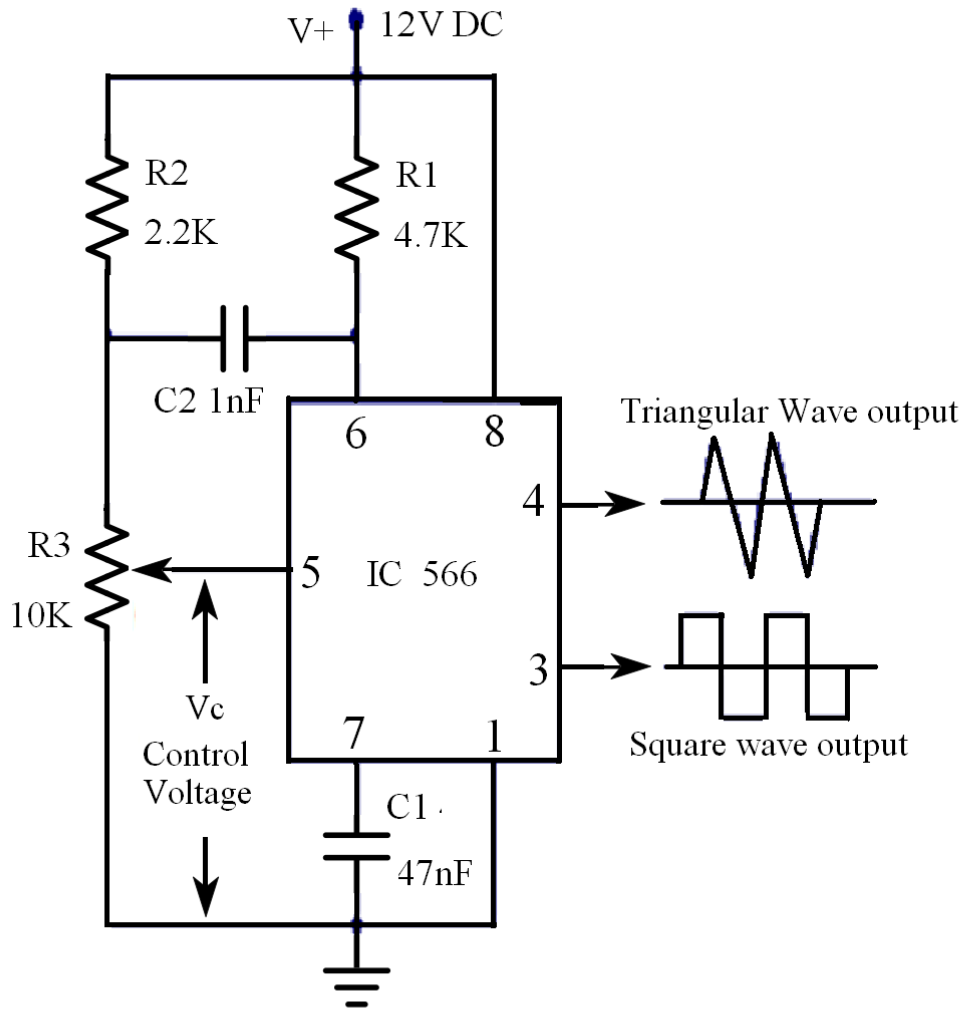

### Block diagram of IC566

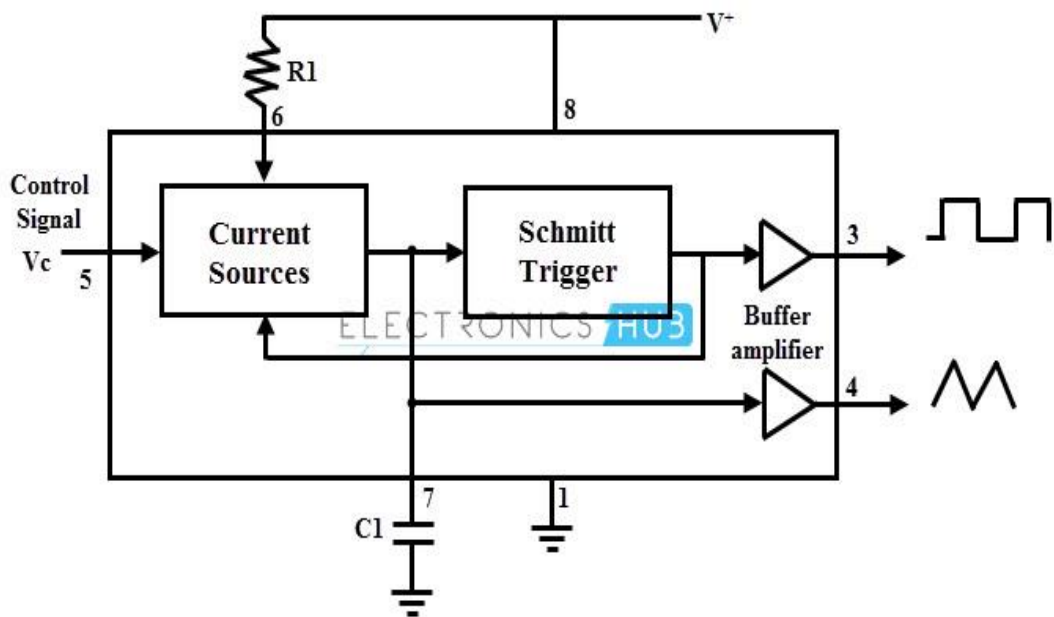

### D, N Packages

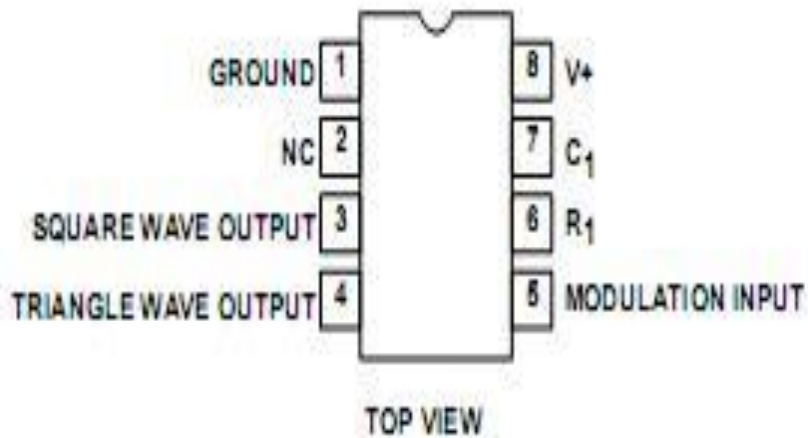

IC 566 Pin details

### Design:

(Optional)

$$f_0 = 5(V_{cc} - V_c) / (2V_{cc}R_1C_1)$$





As per data sheet  $(3/4V_{cc}) < V_c < V_{cc}$  and  $2K < R < 20K$ , Output frequency up to 1MHZ

Let  $V_{cc} = 12V$ ,  $f_0 = 2 \text{ KHz}$ ,  $V_c = (3 / 4 V_{cc}) = 10 \text{ V}$

Choose  $R_1 = 4.7K$

Then  $C_1 = 47nF$ , Take  $C_2 = 1nF$

$V_c = V_{cc} R_3 / (R_2 + R_3) = 3/4V_{CC} = 10V$

Choose  $R_2 = 2.2K$ ,

Then  $R_3 = 10K$  Choose  $R_3 = 10K$  potentiometer.

By varying  $R_3$  control voltage  $V_c$  is varied and hence the output frequency

**Observations:**

$f_0 = ?$

Sl.No	$V_c$ (volts)	$F_0$ (KHz)

**Graph:**



## Experiment No. 12

### VOLTAGE REGULATOR USING IC723

**Aim:** To set up a low voltage regulator using IC723 and plot the regulation characteristics.

**Objectives:** After completion of this experiment the student will be able to construct voltage regulator using IC 723 for the required voltage and know about regulation characteristics

#### Equipments/Components:

Sl. No.	Name and specifications	Quantity
1	Variable Power Supply (0- 30 V)	1
2	Resistors, rheostat	3
3	Capacitor	2
4	IC 723	1
5	Volt meter (0-30V) Voltmeter (0-10V)	1 1
6.	Ammeter (0-10 mA)	1
7	Bread board	1
8	Connecting Wires	As required

#### Principle:

Type 723 is the most versatile of the monolithic voltage regulators. It can be used to provide high and low positive regulated voltages. Current can be boosted to provide 5A or more. It has short circuit protection. The input voltage of IC723 vary from 9.5V to 40V and provide output voltage from 2V to 37V.

IC 723 regulator has two separate sections. One section provides a fixed voltage of 7.15v at the terminal  $V_{ref}$ , other section consists of an error amplifier. These two sections are not internally connected. For constructing low voltage regulator using 723,  $V_{ref}$  point is connected through a resistance to the non-inverting terminal and the output is feedback to the inverting terminal of the error amplifier. If the output voltage becomes low, the voltage at the inverting terminal of error amplifier also goes down. Thus make the output of the error amplifier become more positive, there by driving transistor more into conduction. This reduces the voltage across transistor and drives more current into the load, causing voltage across the load to increase. Thus the initial decrease in the load voltage is compensated. Similarly any increase in the load voltage gets regulated.



**Procedure:**

1. Check all the components
2. Set up circuit on the breadboard and check the connections
3. Switch on the power supply
4. Vary the input dc voltage and measure the input and output voltages using voltmeter
5. Vary the load resistance potentiometer and measure output voltage and current
6. Plot line regulation and load regulation characteristics on the graph
7. Calculate percentage load regulation

**Result :**

**Inference:**

**Circuit Diagram:**

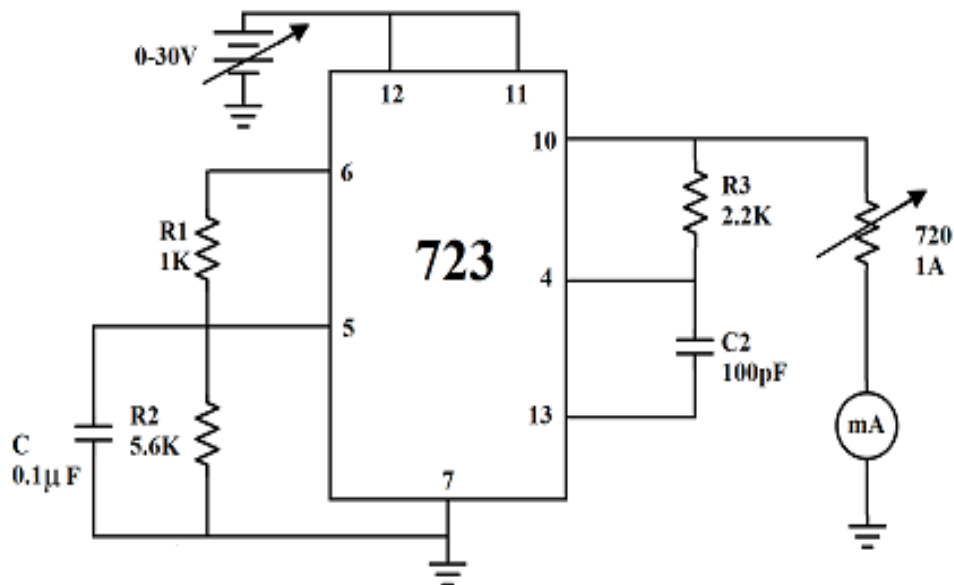

*IC 723 internal block diagram*

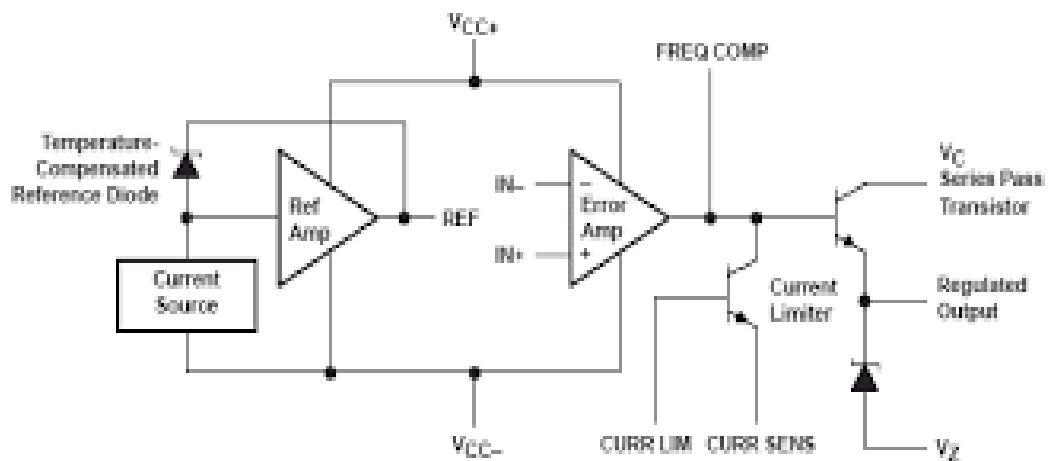

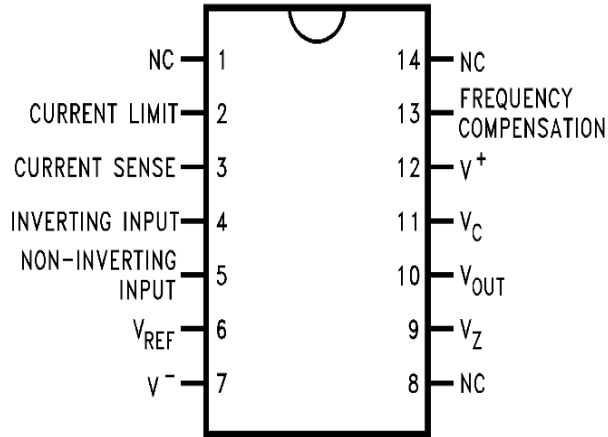

**IC 723 Pin details**

**Design:**

(Optional)

Let the regulated output voltage  $V_o = 6V$

$$V_o = V_{ref} \times \left\{ \frac{R_2}{R_1 + R_2} \right\}$$

$$6 = 7.15 \times \frac{R_2}{R_1 + R_2}$$

Let the current through resistor  $R_1$  and  $R_2$   $I_1 = 1mA$

$$\text{Then } R_1 = \frac{(V_{ref} - V_o)}{I_1} = \frac{(7.15 - 6)}{1mA} = 1.1K = 1K \text{ (std)}$$

$$\text{Then } R_2 = \frac{6}{1.15} = 5.6K \text{ (std)}$$

For room temp. Stability  $R_3 = R_1 \parallel R_2$

As per data sheet  $966 \Omega < R_3 < 3.52K$

Take  $R_2 = 2.2K$ , choose  $C_1 = 0.1\mu F$  and  $C_2 = 100PF$



**Observations:**

Sl.No	<b>V<sub>i</sub></b> (volts)	<b>V<sub>o</sub></b> (volts )

Sl.No	<b>V<sub>o</sub></b> (volts)	<b>I<sub>o</sub></b> (amps)

Percentage load regulation =  $\{(V_{NL}-V_{FL})/V_{NL}\} \times 100 \% = ?$

**Graph:**



## Experiment No. 13

### 5V REGULATED POWER SUPPLY USING IC 7805

**Aim:** To construct a +5v, 1A Power supply using IC 7805

**Objectives:** After completion of this experiment the student will be able to construct + 5V 1A power supply using IC7805 and must have knowledge about 78xx series and 79xx series

#### Equipments /Components:

Sl. No.	Name and specifications	Quantity
1	Multimeter	1
2	Diode 1N4007	2
3	Capacitor	3
4	IC 7805	1
5	Transformer (230 / 6-0-6 , 1A)	1
6	Bread board	1
7	Connecting Wires	As required

#### Principle:

The 78xx family is commonly used in electronic circuits where a regulated power supply is required due to their ease of use and low cost. IC 7805 has a 5volt output. The 78xx series are positive voltage regulator, while 79xx devices are negative voltage regulators. IC 7805 has 3 terminals. 7805 can deliver up to 1.5A current. The device may get damaged if there is any deviation from the rated voltage, A regulated power supply is very much essential for several electronics devices. The AC power gets converted into constant DC by this circuits. The circuit is made up of linear voltage regulator 7805 along with capacitors and resistors with a full wave rectifier. A regulator is employed with capacitor connected in parallel to the input terminal and the output terminal. The capacitor C2 is bypass capacitor and is employed to bypass extremely tiny duration spikes to ground. C1 is the filter capacitor employed in the circuit to steady the slow alterations in the voltage.

#### Procedure:

1. Check all the components
2. Set up circuit on the breadboard and check the connections
3. Switch on the AC supply
4. Measure input AC and output DC voltages using multimeter.

#### Result:

#### Inference:



**Circuit Diagram:**

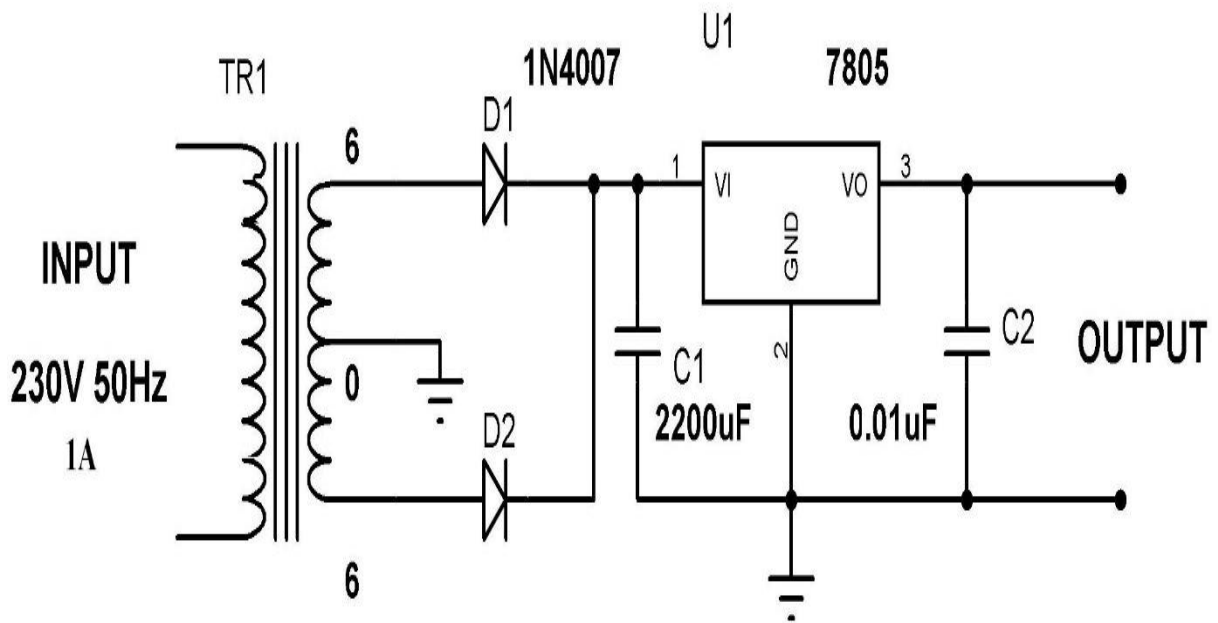

1N4007

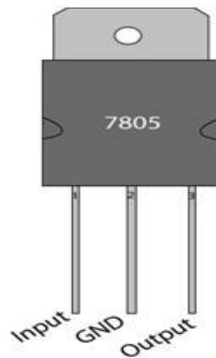

IC 7805 pin details

**Observations:**

AC input voltage =?

Dc output voltage =?





## Experiment No. 14

### VARIABLE POWER SUPPLY USING LM317

**AIM:** To construct variable power supply using IC LM317

**Objectives:** After completion of this experiment the student will be able to construct variable power supply using IC LM317 and must have knowledge about LM317

**Equipments/Components :**

Sl. No.	Name of item & specifications	Quantity
1	Multimeter	2
2	Resistor	1
3	Potentiometer	1
4	Capacitor	3
4	IC LM 317	1
5	Transformer (230 / 12 V)	1
7.	Diode 1N4001	4
8	Bread board	1
9	Connecting Wires	As required

#### Principle:

IC LM 317 is an adjustable linear voltage regulator. LM 317 has 3 pin. Input, Output and adjustment. Its output voltage range is from 1.25 - 37 V and maximum output current is 1.5A. The device is conceptually an op-amp with relatively high output current capacity. The non-inverting input of the op-amp is the adjustment pin while the inverting input is set by an internal voltage reference of 1.25V. A resistive voltage divider between the output and ground configures the op-amp as a non-inverting amplifier. So that the voltage of the output pin is continuously adjusted to a fixed amount of reference voltage. In the circuit transformer steps down to AC 230V to 12V and is applied to bridge rectifier diodes D1 to D4. C1 and C2 are filter capacitors. Capacitor C3 is for the better performance of filter IC. The output voltage from IC depending on the voltage ADJ pin of the IC. The voltage across variable resistor R2 controls the DC output.  $V_{out} = 1.25 (1 + R_1 / R_2)$  . By varying the resistor R<sub>2</sub> DC output voltage can be varied

#### Procedure:

1. Check all the components
2. Set up circuit on the breadboard and check the connections
3. Switch on the AC supply



<https://mail.gptcthirurangadi.in>

4. Measure AC input and DC output voltages using multimeter
5. Vary the potentiometer R2 to vary the DC output voltage

**Result:**

**Inference:**

**Circuit diagram:**

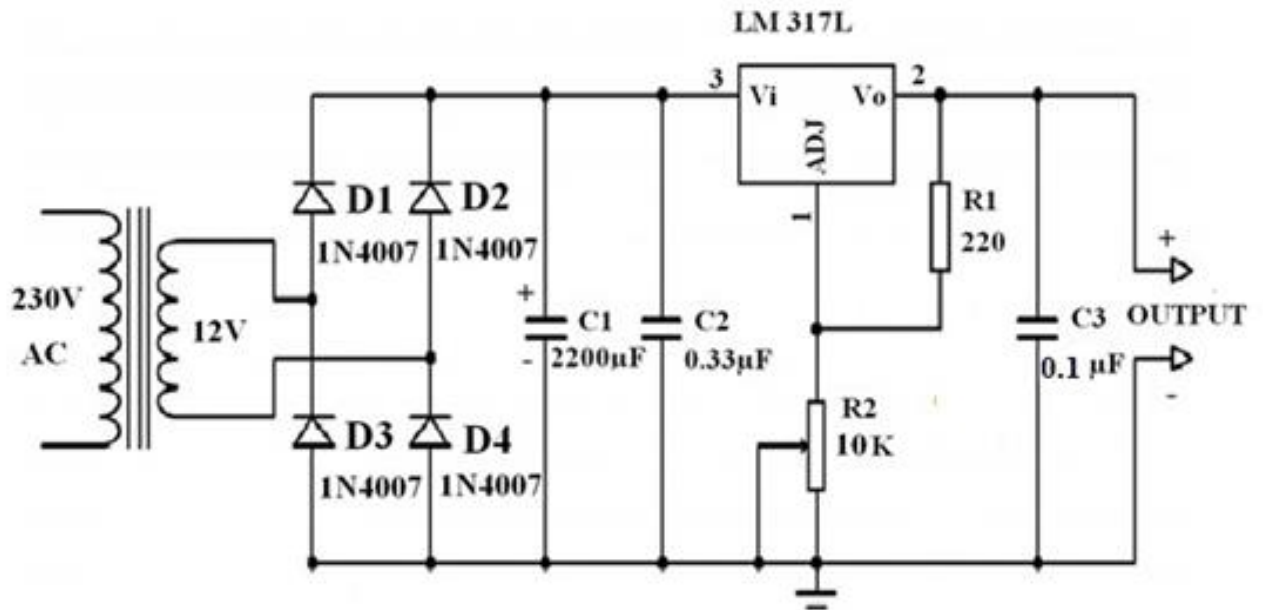

**REGULATOR PINOUT**

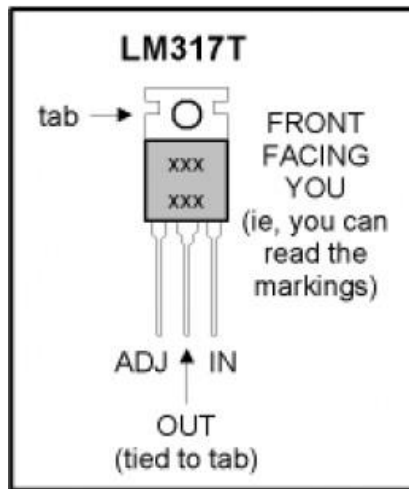

**Observations:**

AC input voltage = ?

Min. DC. Output voltage =?

Max. DC. Output voltage =?



## Experiment No: 15

### DUAL POWER SUPPLY USING LM 320 & LM340

**Aim:** To construct a dual power supply using LM320 and LM340

**Objectives:** After completion of this experiment the student will be able to construct regulated dual DC power supply using ICLM 320 and IC LM 340

#### Equipments / Components :

Sl. No.	Name of item & specifications	Quantity
1	Multimeter	2
2	IC LM340T- 5	1
3	IC LM320K-5	1
4	Capacitor	4
5	Resistors	1
6	Transformer (230 / 9V)	1
7	Diode 1N4001	8
8	Bread board	1
9	Connecting Wires	As required

#### Principle:

Dual power supplies can be easily designed with the help of two 3 terminal regulators LM320 and LM340. The single full wave bridge rectifier converts input AC signal into positive and negative DC output voltage. The voltage across the resistor is filtered with the help of capacitors C1 and C2 and connected to the voltage regulator ICs. While the LM340 provides regulation of the positive voltage, the LM320 regulates the negative voltage. The LM340T-5 gives +5v output while LM320K-5 gives -5V output the diodes D5-D8 in the LM circuit are used to provide protection.

#### Procedure:

1. Check all the components
2. Set up circuit on the breadboard and check the connections
3. Switch on the ac supply
4. Measure input and output voltages using multimeter

#### Result:

#### Inference:

**Circuit Diagram:**

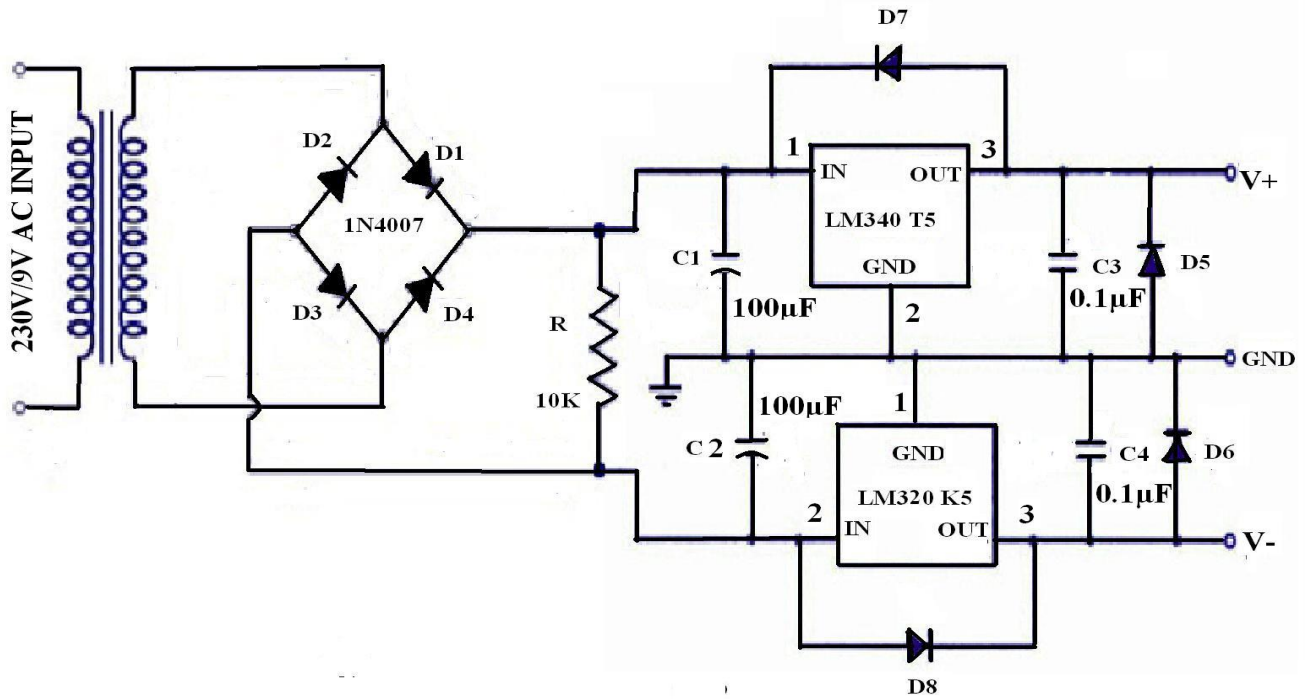

$C1 = C2 = 100\mu\text{F}$ ;  $c3 = c4 = 0.1\mu\text{F}$ ; Diodes = 1N 4007 Transformer 230/6 V

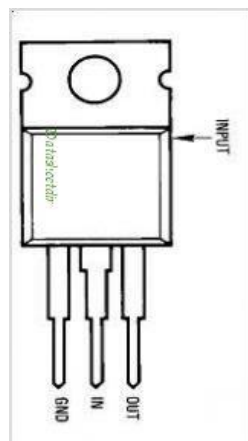

**LM 320 pin details**

**LM 340 pin details**

- Pin 1. Input
- 2. Ground
- 3. Output



Heatsink surface is connected to Pin 2.



<https://mail.gptcthirurangadi.in>

**Observations:**

AC input voltages =?

DC output voltages =?