



N19-00139

TED (15) – 2005

Reg. No. ....

(REVISION — 2015)

Signature .....

**DIPLOMA EXAMINATION IN ENGINEERING/TECHNOLOGY/  
MANAGEMENT/COMMERCIAL PRACTICE — OCTOBER, 2019**

**ENGINEERING GRAPHICS**

[Time : 3 hours

(Maximum marks : 100)

- [Note : — 1. A2 size drawing sheet to be supplied.  
2. First angle projection to be followed.  
3. Dimensions should be as per BIS.  
4. Both sides of drawing sheet can be used.  
5. Sketches accompanied.]

**PART — A**

(Maximum marks : 10)

Marks

- I Answer *all* questions in one or two sentences. Each question carries 2 marks.
1. Write any four elements of dimensioning.
  2. What is an involute ?
  3. Draw the symbol of first angle projection.
  4. What do you mean by orthographic projection ?
  5. Write the expansion of CADD.

(5×2= 10)

**PART — B**

(Maximum marks : 50)

(Answer any *five* of the following questions. Each question carries 10 marks.)

- II Redraw the given figure -1 to full size and dimension it as per BIS.
- III Draw a parabola of base 90 mm and axis 60 mm using tangent method.
- IV Construct a regular heptagon of side 30 mm.
- V Construct a plane scale of RF = 1:40 to show meters and decimetres and long enough to measure up to 5 meters. Mark on the scale a distance representing 4.3 meters.
- VI Draw projections of the following points on a common reference line.
  - (i) Point A is 30 mm in front of VP and 40 mm above HP.
  - (ii) Point B is 25 mm below HP and 50 mm behind VP.
  - (iii) Point C is in the VP and 30 mm above HP.



- (iv) Point D is 40mm below HP and 20 mm in front of VP.  
(v) Point E is in both HP and VP.
- VII Draw the projections of a square lamina of size 40 mm is inclined  $30^\circ$  to HP and perpendicular to VP.
- VIII Draw the development of a funnel shown in figure- 2.

(5×10= 50)

PART — C

(Maximum marks : 40)

(Answer any *two* of the following questions. Each full question carries 20 marks.)

- IX Isometric view of a shaft support is shown in figure - 3. Draw the front view in the direction of F, Top view and left side view.
- X Pictorial view of an object is shown in figure - 4. Draw the full sectional front view in the direction of F and top view.
- XI Orthographic views of an object are shown in figure - 5. Draw the isometric view of the object.

(2×20= 40)

TED (15) – 2005

(i)

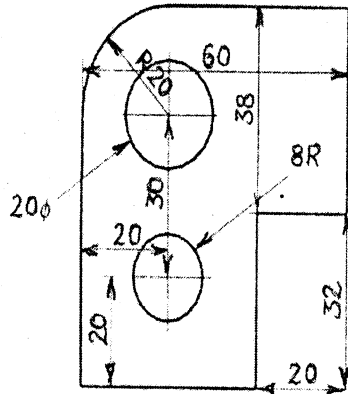

Fig-1

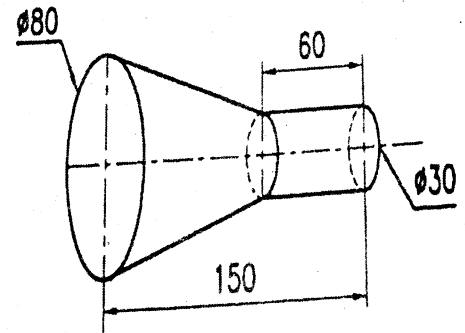

Fig-2

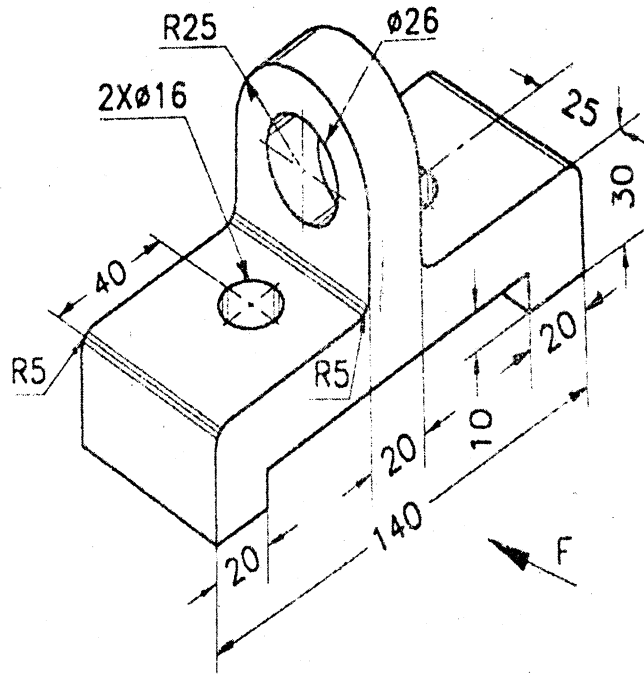

Fig (3)

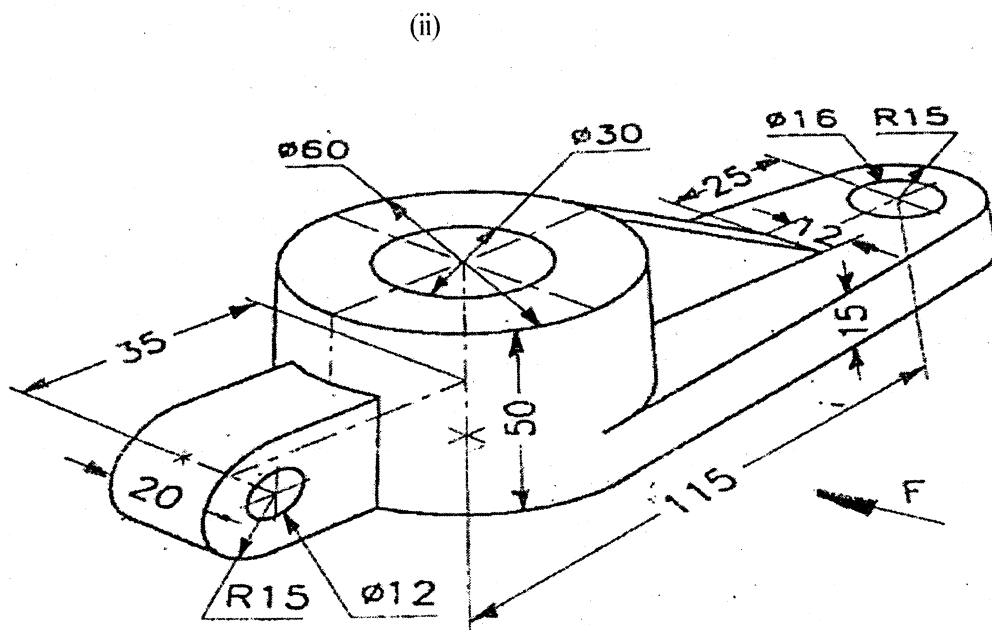

Fig - 4

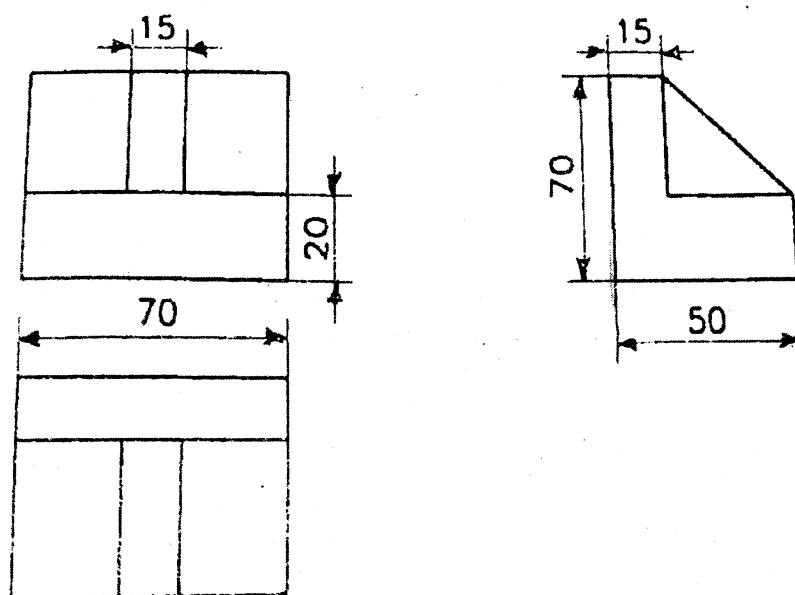

Fig - 5