



TED (15) 2005-A
(Revision-2015/19)

A21-04060

Reg.No.....
Signature.....

**DIPLOMA EXAMINATION IN ENGINEERING/TECHNOLOGY/MANAGEMENT/
COMMERCIAL PRACTICE, APRIL-2021**

ENGINEERING GRAPHICS

[Maximum marks: 75]

(Time: 2.15 Hours)

- (Note: 1. Any missing data may suitably assumed
2. Sketches are accompanied
3. All drawings should be in first angle projection)

PART – A

I (Answer any **three** questions in one or two sentences. Each question carries 2 marks)

1. What is the necessity of dimensioning?
2. Define eccentricity of conic section.
3. What is meant by profile plane of projection?
4. What is meant by development of surface?
5. Write any four commands used in Auto Cad.

(3 x 2 = 6)

PART – B

(Answer any **four** of the following questions. Each question carries 11 marks)

- II. Redraw the drawing shown in figure-1 and dimension it as per BIS code of dimensioning.
- III. Draw a regular pentagon of side 40mm using two circles and an arc method.
- IV. Draw a conic section whose eccentricity is equal to one and distance between focus and directrix is equal to 50mm. Also draw a tangent and normal to any point on curve.
- V. Draw the orthographic projections of following points about a reference line XY. Distance between projectors is 30mm.
Point P is 30mm above HP and 40mm in front of VP
Point Q is 25mm above HP and 35mm behind VP.
Point R is 32mm below HP and 38mm behind of VP.
Point S is 36mm below HP and 15mm in front of VP.
- VI. A line AB 60mm long has its end A in HP and 20mm in front of VP. If line is 45° inclined to HP and 30° to VP draw its projections and find the apparent inclinations to HP and VP.



VII. A circular lamina of 60mm diameter is 30° inclined to HP and perpendicular to VP so that centre of lamina is 40mm in front of VP and lowest circular edge is 14mm above HP. Draw its projections.

VIII. A square pyramid of 50 mm base and 70 mm height is resting on one of its base edges on HP. If axis is parallel to VP and 45° inclined to HP, draw its projections. (4x11=44)

PART – C

(Answer *any one* question from the following. Each question carries 25 marks)

IX. Figure II shows the pictorial view of a shaft support. Draw its front view in the direction of F, top view left side view.

X. Figure III shows orthographic views of an object. Draw its isometric view to full scale.

XI. Develop the lateral surface of 90 degree pipe elbow. Each pipe of elbow is 400mm and length of one leg is 600 mm. (1x25=25)

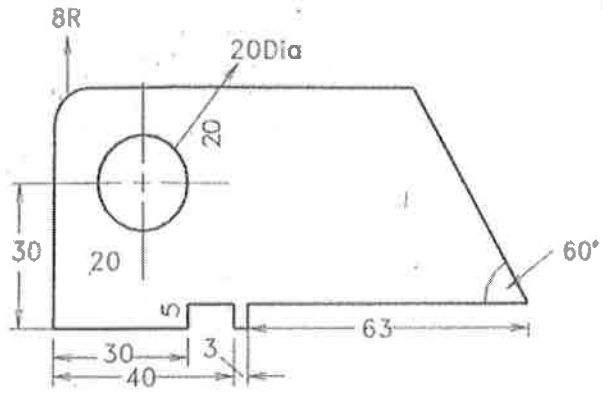

FIG -I

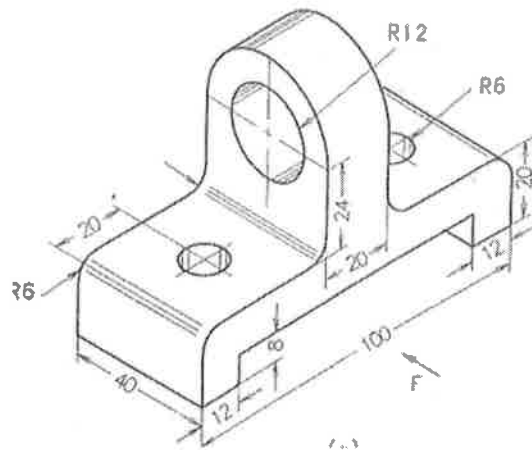

FIG-II

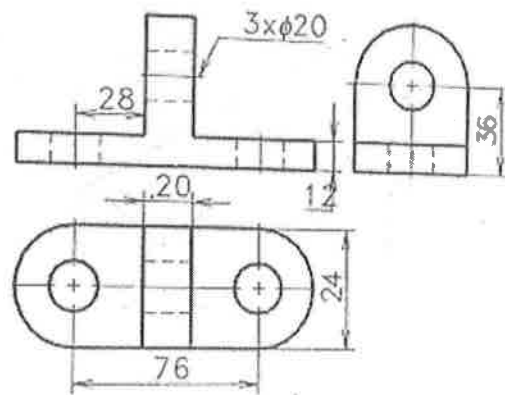

FIG -III
